

Thermo Scientific

# TRACE GC Ultra

Gas Chromatograph

## Site Preparation and Installation Manual

PN 31709190, Revision May 2007

HOME



## **TRACE™ GC Ultra Site Preparation and Installation Manual**

**May 2007 Edition**

Part Number 317 091 90

© 2007 Thermo Fisher Scientific Inc. All rights reserved.

Printed in Italy

Published by Thermo Electron S.p.A., Strada Rivoltana, 20090 Rodano - Milan - Italy

Tel: +39 02 95059355 Fax: +39 02 95059388

Printing History: First Edition, released June 1998.

Second Edition, released November 1998.

Third Edition, released June 1999

Fourth Edition, released June 2001

Fifth Edition, released January 2002

Sixth Edition, released May 2003

Seventh Edition, released April 2004

Eighth Edition, released January 2005

Ninth Edition, released September 2005

Tenth Edition, released January 2007

Eleventh Edition, **released May 2007**

### **Disclaimer**

Technical Information contained in this publication is for reference purposes only and is subject to change without notice. Every effort has been made to supply complete and accurate information; however, Thermo Fisher Scientific assumes no responsibility and will not be liable for any errors, omissions, damage, or loss that might result from any use of this manual or the information contained therein (even if this information is properly followed and problems still arise).

This publication is not part of the Agreement of Sale between Thermo Fisher Scientific and the purchaser of a TRACE™ GC Ultra system. In the event of any conflict between the provisions of this document and those contained in Thermo Fisher Scientific's Terms and Conditions, the provisions of the Terms and Conditions shall govern.

Reference to System Configurations and Specifications supercede all previous information and are subject to change without notice.

### **Trademarks**

TRACE™ GC Ultra is a trademark of Thermo Fisher Scientific Inc., and its subsidiaries. Other brand and product names may be trademarks or registered trademarks of their respective companies.

# Declaration

**Manufacturer: *Thermo Electron S.p.A.***

Thermo Electron S.p.A. is the manufacturer of the instrument described in this manual and, as such, is responsible for the instrument safety, reliability and performance only if:

- installation
- re-calibration
- changes and repairs

have been carried out by authorized personnel and if:

- the local installation complies with local law regulations
- the instrument is used according to the instructions provided, and if its operation is only entrusted to qualified, trained personnel

Thermo Electron S.p.A. is not liable for any damages derived from the non-compliance with the aforementioned recommendations.

**Thermo Electron S.p.A.**

Strada Rivoltana  
20090 Rodano (MI)  
ITALY

---



# Contents

<b>About This Manual</b> .....	<b>ix</b>
Overview .....	ix
Conventions Used in This Manual .....	x
Instrument Markings and Symbols .....	xii
Using the TRACE GC Ultra Document Set.....	xv

## SECTION I

### Site Preparation

#### Chapter 1

<b>Laboratory Preparation</b> .....	<b>19</b>
Entrance.....	20
Space and Load Requirements .....	21
Power Requirements .....	23
120 V ac Power Requirements.....	23
230 V ac Power Requirements.....	23
Power Quality .....	23
Effects of Voltage Disturbances .....	24
Wall Outlets .....	24
Technical Assistance.....	27
Operating Environment.....	27
Temperature .....	27
Cooling Requirements .....	27
Oven Exhaust .....	29
Altitude.....	29
Humidity .....	29
Particulate Matter .....	29
Electrostatic Discharge .....	30
Vibration .....	30
Lighting.....	30
Other Environmental Factors .....	31
Exhaust System .....	31
Gas and Plumbing Requirements .....	31
Gas Purity.....	33
Traps .....	33
Purity Requirements.....	34
Gas Regulators and Fittings.....	35

## Contents

Secondary Gas Regulators.....	36
Gas Tanks.....	36
Gas Lines.....	36
Gas Lines for Cold On-Column Injectors.....	37
Cryogenic Cooling.....	37
Liquid Nitrogen.....	38
Liquid Carbon Dioxide.....	39
Telephone.....	40
Required Tools.....	40
Supplemental Equipment.....	41
Hardware and Software Minimum Requirements.....	42
ChromQuest Data System.....	42
Hardware Requirements.....	42
Operating System Requirements.....	42
Chrom-Card Data System.....	43
Hardware Requirements.....	43
Operating System Requirements.....	43

## Chapter 2

<b>Instrument Arrival.....</b>	<b>45</b>
Shipping Information.....	45
Origin.....	45
Destination.....	46
Receiving Instruments.....	46
Installation.....	47
Training.....	48

## SECTION II

### Installation

## Chapter 3

<b>Before You Begin.....</b>	<b>51</b>
Verify Site Preparation.....	51
Unpacking the Instrument.....	51
Gas Plumbing Basics.....	53
How to Use a Tubing Cutter.....	53
How to Use Teflon Tape on Pipe Threads.....	53
How to Use Swagelok Tube Fittings.....	54

How to Attach a Swagelok Tee or Cross .....	56
<b>Chapter 4</b>	
<b>Plumbing the Gas Supply to the GC .....</b>	<b>57</b>
Using Hydrogen .....	58
Using the Hydrogen Sensor .....	59
Building the Gas Lines .....	60
Connecting the Gas Supply Cylinders .....	60
Adding Traps to the Gas Supply .....	61
Purging Gas Lines .....	62
Connecting the Gas Supply to the Inlet Manifold .....	63
Connecting the Gas Supply to the Detector Manifold .....	63
Connecting Coolant to the Cryogenic System .....	66
Column Oven Cryo System .....	66
PTV Injector Cryo System .....	66
Testing for Leaks .....	67
<b>Chapter 5</b>	
<b>Getting Connected .....</b>	<b>69</b>
Introduction .....	69
Remove the TRACE Cover .....	69
Connect the Data System .....	70
Connect the Computer Cable .....	71
Connect the LAN Cable .....	72
Connect the Autosampler .....	73
Computing Integrators .....	76
System Power Up .....	77
<b>Appendix A</b>	
<b>Preinstallation Checklist .....</b>	<b>79</b>
<b>Appendix B</b>	
<b>Customer Communication .....</b>	<b>81</b>
How To Contact Us .....	81
Reader Survey .....	82
<b>Glossary .....</b>	<b>83</b>

**Contents**

**Index ..... 89**

# About This Manual

## Overview

---

The *Site Preparation and Installation Manual* will help you prepare for the arrival and installation of your TRACE GC Ultra gas chromatograph. Following the procedures and guidelines in this manual will help the installation process go smoothly.

This manual is organized as follows:

Section I, *Site Preparation*, contains the information you need to prepare for the arrival of your TRACE GC Ultra gas chromatograph system. In addition to laboratory and operating environment standards, this section contains information about the shipping and delivery of your TRACE system.

Chapter 1, *Laboratory Preparation*, gives you all the information you need to prepare your laboratory for the arrival of your TRACE system.

Chapter 2, *Instrument Arrival*, gives an overview of shipping and receiving procedures, installation, and training.

Section II, *Installation*, contains information to help you set up and install your TRACE GC Ultra gas chromatograph.

Chapter 3, *Before You Begin...*, contains unpacking instructions and provides a brief tutorial of basic gas plumbing operations you must know before you can continue the installation process.

Chapter 4, *Plumbing the Gas Supply to the GC*, explains the proper gas supply connections and configuration information for your GC.

Chapter 5, *Getting Connected*, explains the TRACE power connections, and helps you mount and configure peripheral devices and data systems.

Appendix A, *Preinstallation Checklist*, contains a step-by-step list of items you should complete before your TRACE system arrives.

Appendix B, *Customer Communication*, contains contact information for Thermo Fisher Scientific offices worldwide. Use the *Reader Survey* in this section to give us feedback on this manual and help us improve the quality of our documentation.



The *Glossary* lists and defines terms used in this guide and the *Site Preparation Help File*. This includes abbreviations, acronyms, metric prefixes, and symbols.

The *Index* contains an alphabetical list of key terms and topics in this guide with cross references and the corresponding page numbers.

## Conventions Used in This Manual

---

The following symbols and typographical conventions are used throughout this manual.

<b>Bold</b>	Bold text indicates names of windows, menus, dialog boxes, buttons, and fields.
<i>Italic</i>	Italic text indicates cross references, first references to important terms defined in the glossary, and special emphasis.
Monospace	Monospace, or Courier, indicates filenames and filepaths, or text the user should enter with the keyboard.
<b>Monospace Bold</b>	Monospace Bold indicates messages or prompts displayed on the computer screen or on a digital display.
»	This symbol illustrates menu paths to select, such as <b>File»Open...</b>
<b>KEY NAME</b>	Bold, uppercase sans serif font indicates the name of a key on a keyboard or keypad, such as <b>ENTER</b> .
 <b>CAUTION</b>	This symbol alerts you to an action or procedure that, if performed improperly, could damage the instrument.
 <b>NOTE</b>	This symbol alerts you to important information related to the text in the previous paragraph.



**WARNING!**

This symbol alerts you to an action or procedure that, if performed improperly, could result in damage to the instrument or possible physical harm to the user. This symbol may be followed by icons indicating special precautions that should be taken to avoid injury.



This symbol indicates electric shock hazard.



This symbol indicates danger from hazardous chemicals.



This symbol indicates danger from high temperature surfaces or substances.



This symbol indicates a fire hazard.



This symbol indicates an explosion hazard.



This symbol indicates a toxic hazard.



This symbol indicates the presence of flammable materials.



This symbol indicates the presence of radioactive material.



This symbol indicates an operation or procedure that must NOT be performed by the user. A Thermo Fisher Scientific authorized Customer Support Engineer must perform this procedure.



This symbol indicates all metal objects, such as watches, jewels, etc., must be taken off.



This symbol indicates an eye hazard. Eye protection must be worn.



This symbol indicates the user must wear a protective screen when performing the procedure.



This symbol indicates the user must wear protective shoes when performing the procedure.







This symbol indicates the user must wear protective clothing when performing the procedure.

















This symbol indicates the user must wear gloves when performing the procedure.

## Instrument Markings and Symbols

The following table explains the symbols used on Thermo Fisher Scientific instruments. Only a few of them are used on the TRACE GC Ultra gas chromatograph.

Symbol	Description
	Direct Current
	Alternating Current
	Both direct and alternating current
	Three-phase alternating current

Symbol	Description
	Earth (ground) terminal
	Protective conductor terminal
	Frame or chassis terminal
	Equipotentiality
	On (Supply)
	Off (Supply)
	Equipment protected throughout by DOUBLE INSULATION or REINFORCED INSULATION (Equivalent to Class II of IEC 536)
	Indicates that the user must refer to the manual for specific Warning or Caution information to avoid personal injury or damage to the product.
	Caution, risk of electric shock
	Caution, hot surface
	Caution (refer to accompanying documents)
	In-position of a bistable push control

Symbol	Description
	<p>Out-position of a bistable push control</p>
	<p>Symbol in compliance to the Directive 2002/96/EC on Waste Electrical and Electronic Equipments (WEEE) placed on the european market after August, 13, 2005.</p>

# Using the TRACE GC Ultra Document Set

---

The TRACE GC Ultra Document Set (CD-Rom PN 317 095 00) includes all manuals in electronic format, and serves as your library for information about the TRACE hardware and software.

The TRACE GC Ultra Document Set (PN 317 093 00) as paper copy is also available. Furthermore, Thermo Fisher Scientific part numbers (PN) for the paper copy manuals are provided for each book title.

*Site Preparation and Installation Manual* (PN 317 091 90)

This manual and diskette describes how to set up a workspace for the TRACE GC Ultra and how to connect the GC to the gas supplies and peripheral devices.

*Acceptance Package* (PN 317 092 20)

This folder contains required shipping documents and quality report forms.

*Getting Started* (PN 317 092 30)

This guide contains procedures for checking configuration, installing detectors, and making a first analysis with the TRACE GC Ultra.

*Operating Manual* (PN 317 091 70)

This manual provides descriptions of the TRACE GC Ultra hardware and software and instructions for their use.

*UFM Ultra Fast Module Device* (PN 317 093 98)

This manual provides descriptions of the TRACE GC Ultra equipped with the UFM device, and instructions for its use.

*Quick Reference Card* (PN 317 092 40)

This reference card contains guidelines for carrier gas use and injection procedures.

*K-Factor Quick Reference* (P/N 317 092 41)

This reference card contains information to interpretate results from a Column Evaluation.

*Preventive Maintenance Schedule* (PN 317 092 80)

This document provides a list of recommended scheduled maintenance and a year-long log book to record maintenance, observations, supply lists, and service records.

*Maintenance and Troubleshooting Guide* (PN 317 091 80)

This manual contains instructions for diagnosing and resolving operational problems.

*Standard Operating Procedures* (PN 317 092 00)

This manual contains instructions, operating procedures, and test criteria for final testing of the TRACE GC Ultra.

*Spare Parts Catalog* (PN 317 092 10)

This catalog contains a list of spare parts for the TRACE GC Ultra.

# SECTION

# I

## Site Preparation

The *Site Preparation* section contains the information you need to prepare for the arrival of your TRACE GC Ultra gas chromatograph. In addition to laboratory and operating environment standards, this section contains information about the shipping and delivery of your TRACE system.

Chapter 1, *Laboratory Preparation*, gives you all the information you need to prepare your laboratory for your TRACE system.

Chapter 2, *Instrument Arrival*, gives an overview of shipping and receiving procedures, installation, and training.





# Laboratory Preparation

This chapter gives you all the information you need to prepare your site for the arrival of your TRACE GC Ultra system. It also includes a list of tools and supplies you need to install your gas chromatograph. The information in this chapter will help you plan, construct, and fully equip your laboratory. Your laboratory must meet the requirements for power, exhaust systems, and environmental conditions explained in this chapter before your gas chromatograph can be installed.

Your laboratory preparations should be completed *before* the TRACE GC Ultra is unpacked. Complete any work that creates dust, high humidity, or corrosive vapors before you begin unpacking the instruments.

## **Chapter at a Glance...**

Entrance .....	20
Space and Load Requirements .....	21
Power Requirements.....	23
Operating Environment .....	27
Exhaust System .....	31
Gas and Plumbing Requirements .....	31
Telephone .....	40
Required Tools.....	40
Supplemental Equipment.....	41
Hardware and Software Minimum Requirements .....	42

TRACE GC Ultra systems operate reliably under controlled environment conditions. Operating or maintaining a system outside the specifications outlined in this guide may cause many different types of system failures. The repair of such failures is specifically excluded from the standard warranty and service contract coverage. Use this chapter to ensure that your site meets all the criteria of the *Preinstallation Checklist* in Appendix A.



**NOTE**

In addition to the information in this chapter, you must also obey the building and safety rules and regulations for construction that apply in your area.

## Entrance

---

The entrance to your facility and the width of all hallways, elevators, and doorways should be at least 92 cm (37 in.).<sup>1</sup> However, you should allow additional room for maneuvering the system around corners, into elevators, or through doorways.

The TRACE GC Ultra and accessories are shipped in a container with the following dimensions:

$l$ —92 cm (37 in.),  $w$ —76 cm (30 in.),  $h$ —88 cm (35 in.)

The container and its contents weigh approximately 65 kg (145 lbs). Other modules, such as the computer, monitor, and options, are shipped in their own containers. Their dimensions and weights are less than those of the TRACE container.

- 
1. Your instrument is shipped in a container, the smallest dimension of which is 92 cm (37 in.). If the entrance to your laboratory will not accommodate a 92 cm (37 in.) container, you can remove the individual modules from the container before moving them into the room. If the instrument is removed from its shipping container before it is delivered to the lab site, be sure that all the contents of the container remain with the instrument.

# Space and Load Requirements

---

We recommend the following space allowances for the area around the gas chromatograph:

- The working area should be at least 1.5 m (5 ft) wide.
- The working area should be 1.5 m (5 ft) deep. The depth includes a 75 cm (30 in.) bench for the gas chromatograph.
- The area behind the instrument should be a minimum of 30 cm (12 in.).

Provide enough space around the instrument for operators to work beside it and in front of it. Keep in mind that the GC oven vents to the rear. Any material exposed to the oven exhaust must withstand repeated exposure to temperatures of up to 400 °C (750 °F).

The space requirements and weights for the standard system components are given in Table 1-1. Similar information for TRACE optional instruments is provided in Table 1-2.

The TRACE system should be placed on a workbench that has minimum dimensions of 0.75 × 2 m (2.5 × 6 ft.). The workbench must also be capable of supporting the weight of the data system computer or computing integrator, 27 kg (60 lb), plus the weight of any options. Be sure there is at least 16 cm (6 in.) of space behind the workbench for connections. In addition, there must be at least 92 cm (36 in.) of vertical clearance from the top of the TRACE system. Therefore, you should avoid placing the instrument below cabinets or shelves.

**NOTE**

To keep the data system computer or integrator close to the electrical connections, we recommend placing it on the right side of the GC.

Use Table 1-1 to determine the minimum space and weight requirements for a standard TRACE system.

**Table 1-1.** Minimum Space and Weight Requirements: TRACE Standard System

Instrument	Height		Width		Depth		Weight	
	cm	in.	cm	in.	cm	in.	kgs	lbs
TRACE GC Ultra	51	20	61	24	66	26	48	105
computer	18	7	44	17	44	17	12	27
monitor	39	15	39	15	39	15	14	30
keyboard	5	2	51	20	21	8	1	2



**NOTE**

The total load on the workbench is 75 kg (164 lbs).

Use Table 1-2 to determine the space and weight requirements for optional instruments for your TRACE system.

**Table 1-2.** Space and Weight Requirements: TRACE Optional Instruments

Instrument	Height		Width		Depth		Weight	
	cm	in.	cm	in.	cm	in.	kgs	lbs
<b>Autosamplers</b>								
AS 2000 Control Module	8.5	3.3	18	7	61	24	6	13
HS 2000 Control Module	8.5	3.3	18	7	61	24	6.5	14
AS 2000 Turret/Tray	50	20	30	12	30	12	8	18
HS 2000 Turret/Tray	64	25	39	15	33	13	10	22
AI 3000 AutoInjector	40	16	23	9	25	10	6	13
AS 3000 Autosampler	40	16	40	16	25	10	6	13
TriPlus	66.7	26.3	87	34.3	77.3	30.4	25	56
TriPlus (extended version)	66.7	26.3	122	48	77.3	30.4	25	56
<b>Printers</b>								
inkjet printer/plotter	20	8	43	17	38	15	4	8
laser printer	29	12	42	17	41	16	20	44



**NOTE**

Other peripheral devices, such as purge and trap units, may be connected to the TRACE GC Ultra. These peripheral devices may have additional bench space requirements. Consult your local Thermo Fisher Scientific Customer Support Engineer (CSE) for assistance.

# Power Requirements

---

It is your responsibility to provide an acceptable source of power. You should provide a dedicated power line with a circuit breaker capable of withstanding the power ratings listed in the following sections.

## 120 V ac Power Requirements

For TRACE GC Ultra systems installed in the US and other countries using 120 V ac power, the *minimum* power requirements are as follows:

- 120 V ac +6, -10%
- frequency of 50/60 Hz  $\pm$  2 Hz
- three duplex outlets (single-phase power) with a minimum power rating of 20 A at each duplex outlet
- earth ground hard-wired to the main panel

## 230 V ac Power Requirements

For TRACE GC Ultra systems installed in countries using 230 V ac power, the *minimum* power requirements are as follows:

- 230 V ac  $\pm$  10%
- frequency of 50/60 Hz  $\pm$  2 Hz
- three duplex outlets, with a minimum power rating of 16 A at each duplex outlet
- earth ground hardwired to the main panel

## Power Quality

The quality of power supplied to your TRACE GC Ultra system must be stable and within the specifications listed in this guide. The line voltage must be free of fluctuation due to slow changes in the average voltage, surges, sags, transients, and harmonics.

The TRACE GC Ultra system operates in an Overvoltage Category II environment, as defined in International Standard EN 61010-1: 1993.

Below are definitions for the most common voltage disturbances:

*Slow average* is a gradual, long-term change in average root mean square (RMS) voltage level, with typical durations greater than 2 s.

*Sags* and *surges* are sudden changes in average RMS voltage level, with typical durations between 50  $\mu$ s and 2 s.

*Transients* (or *impulses*) are brief voltage surges of up to several thousand volts, with durations of less than 50  $\mu$ s.

*Harmonic distortion* is a high-frequency disturbance that appears as distortion of the fundamental sine wave. Total harmonic distortion should be less than 3%.

## Effects of Voltage Disturbances

Constant high line voltage or surges in voltage can cause overheating and component failures. Constant low line voltage or sags in voltage can cause the system to function erratically. Transients, even of a few microseconds duration, can cause electronic devices to fail catastrophically or to degrade, shortening their lives significantly. Harmonic distortion can cause noise in power supply lines and degrade the performance of the instrument. Therefore, it is important to establish the quality of the line power in your laboratory prior to the installation of your TRACE system.



### NOTE

The interconnected power outlets for the TRACE system require a common point to one ground connector. If there are two such points, with each connected to separate external grounds, noise current will flow through the ground system via the ground loop that is formed.

## Wall Outlets



### NOTE

The power cable from the TRACE GC Ultra is approximately 3 m (9 ft) long.

Use an Uninterruptible Power Source (UPS) to protect your data system against possible loss due to power outages. At this time, we do not recommend using a UPS with the GC.

Most UPS systems are not designed to provide high-quality distortion-free power for scientific equipment.

The 120 V ac systems are fitted with U.S. standard National Electronics Manufacturers Association (NEMA) 5-20P power plugs. A NEMA 5-20P power plug and its corresponding outlet are rated at 20 A and 125 V ac.

The power cables from the personal computer, monitor, and printer are approximately 2 m (6 ft) long. The 120 V ac systems are fitted with NEMA 5-15P plugs. For optional instruments, the plug requirements may vary. Refer to your product's user manual for specifications.

Figure 1-1 shows the NEMA power plugs and outlets.

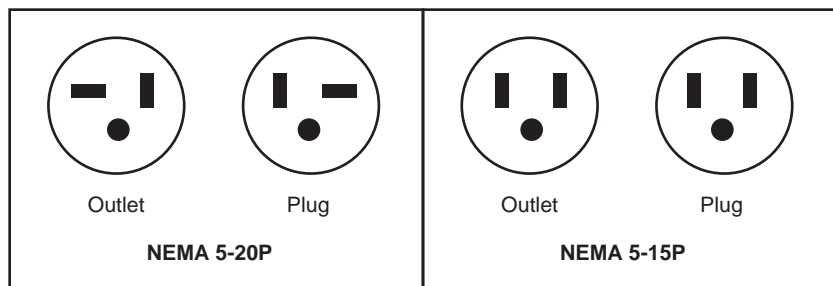

**Figure 1-1.** NEMA 5-20P and 5-15P Power Plugs and Outlets: 120 V ac

The 230 V ac systems are fitted with Shuco German-type power plugs. Plug requirements are dictated by country. Figure 1-2 shows the Shuco power plug and outlet.

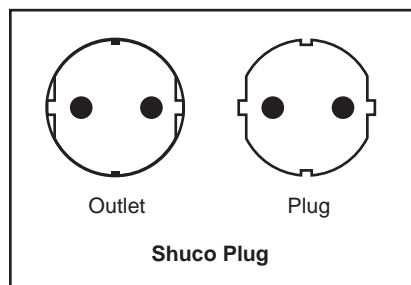

**Figure 1-2.** Shuco 230 V ac Power Plugs and Outlets



**CAUTION** You should never connect the TRACE GC Ultra and its peripheral devices to the same electrical wall outlet. You will run the risk of overloading the circuit.

Tables 1-3 and 1-4 show maximum current requirements for the TRACE GC Ultra system and optional instruments.

**Table 1-3.** Maximum Current Requirements for the TRACE Standard System

Instrument	120 V Current Requirement (in amperes)	230 V Current Requirement (in amperes)
TRACE GC Ultra	20	10
computer	4	2
monitor	2	1
<b>Total</b>	26	13

**Table 1-4.** Maximum Current Requirements for TRACE Optional Instruments

Instrument	120 V Current Requirement (in amperes)	230 V Current Requirement (in amperes)
<b>GC Autosamplers</b>		
AS 2000	0.8	0.4
HS 2000	1.6	0.8
AI 3000 / AS 3000	0.6	0.3
TriPlus	2	1
<b>Printers</b>		
ink jet printer/plotter	1.8	0.9
laser printer	7	3.5



**NOTE**

Other peripheral devices, such as purge and trap units, may be connected to the TRACE GC Ultra. These peripheral devices may have additional power requirements. Consult your local Thermo Fisher Scientific CSE for assistance.

## Technical Assistance

Occasionally, unacceptable quality in line power sources may adversely affect the operation of a TRACE system. It is the user's responsibility to correct line voltage problems.

Specifying power conditioning equipment is a complex task that is best handled by a company or consultant specializing in that field.

Contact your Thermo Fisher Scientific CSE for assistance in locating a power consultant. Refer to Appendix B for a Thermo Fisher Scientific office in your area.

## Operating Environment

---

The operating environment in your laboratory is affected by such factors as temperature, humidity, particulate matter, and electrostatic discharge. It is your responsibility to provide an acceptable operating environment for your TRACE system.

Attention to the operating environment will ensure continued high performance of your gas chromatograph.

## Temperature

The room temperature must be maintained between 18 and 35 °C (65 and 95 °F), and should remain consistent. As the laboratory temperature increases, system reliability decreases.



### NOTE

All electronic components generate heat while operating. This heat must be dissipated to the surrounding air for the components to operate reliably.

### Cooling Requirements

There must be a good flow of air around the system, and the air conditioning must be capable of maintaining a constant temperature (within the operational limits). Any costs for air conditioning are more than offset by good sample throughput and reduced repair costs.



**CAUTION** Do not directly expose the GC system to any cooling duct outlets.

The air conditioning load for a basic TRACE system is approximately 2,650 W (9,100 Btu h<sup>-1</sup>). Table 1-5 and Table 1-6 show the approximate heat output for a TRACE standard system and TRACE optional instruments.

**Table 1-5.** Heat Output: TRACE Standard System

Instrument	Heat Output (in BTU h <sup>-1</sup> )
TRACE GC Ultra	6,600
computer	1,650
monitor	850
<b>Total</b>	<b>9,100</b>

**Table 1-6.** Heat Output: TRACE Optional Instruments

Instrument	Heat Output (in BTU h <sup>-1</sup> )
<b>GC Autosamplers</b>	
AS 2000	550
HS 2000	820
AI 3000 / AS 3000	341.5
TriPlus	752
<b>Printers</b>	
ink jet printer/plotter	200
laser printer	2,900



**NOTE**

Other peripheral devices, such as purge and trap units, may be connected to the TRACE GC Ultra. These peripheral devices may have additional cooling requirements. Consult your local Thermo Fisher Scientific CSE for assistance.

## Oven Exhaust

The GC oven exhaust vents are in the rear of the instrument. Hot air (400 °C [750 °F]) exits through these vents during GC operation. As stated under *Space and Load Requirements* in this chapter, there should be at least 30 cm (12 in.) free space behind the instrument to allow the exhaust to dissipate. Any material exposed to the oven exhaust must be able to withstand repeated exposure to temperatures of up to 400 °C (750 °F).



**WARNING!** Oven exhaust can cause severe burns. Avoid working behind the instrument when the oven vents during cooling-down cycles. Do not expose gas tanks or bottles, chemicals, regulators, electrical cords, or other temperature-sensitive items to oven exhaust.

## Altitude

The maximum operating altitude for the TRACE GC Ultra is 2,000 meters above sea level.

## Humidity

The relative humidity of the operating environment must be between 40 and 80% with no condensation.

Operating your TRACE GC Ultra system in low humidity will cause the accumulation and discharge of static electricity, which shortens the life of electronic components. Operating your GC system in high humidity causes condensation, which can lead to short circuits. High humidity also blocks traps on cooling fans.

We recommended you equip your laboratory with temperature and humidity monitors to ensure your laboratory is always within the required temperature and humidity specifications.

## Particulate Matter

The air in your laboratory must not have excessive dust, smoke, or other particulate matter. The air should contain fewer than 1,000,000 particles per cubic meter (100,000 particles per cubic foot) larger than 5 µm.

Dust can clog the air traps causing a reduction in air flow around electronic components. Dust will also form a layer on electronic components that will act as an insulating blanket, reducing the transfer of heat from the components to the surrounding air.

## Electrostatic Discharge

The TRACE GC Ultra, with all its covers in place, is not susceptible to static discharge. However, laboratory conditions that expose instrumentation and laboratory personnel to repeated high levels of static discharge should be considered a safety hazard.

Therefore, we recommend you take the following precautions, especially if you are operating your system at the lower end of the relative humidity specification listed above.

- Use a static-dissipating floor covering (such as tile or conductive linoleum) in the room housing your instrument.
- Use laboratory chairs covered with natural fibers or other static-dissipating material.
- Wear laboratory coats and clothing made from natural fibers or other static-dissipating material.
- Do not place polystyrene (foam) cups or packing materials on the instrument.

## Vibration

Place your instruments on surfaces that are free of vibration. Be aware of vibrations caused by equipment in adjoining locations.

## Lighting

Overhead lighting is recommended to light your work area.

## Other Environmental Factors

The TRACE GC Ultra operates in an environment where normally only non-conductive pollution occurs, but in which temporary conductivity due to condensation must be expected. This is a Pollution Degree 2 environment, as specified in International Standard EN 61010-1: 1993.

## Exhaust System

---

Specialized exhaust systems generally are not required for GC detector systems. However, it is your responsibility to see that local exhaust codes are followed.

You should be aware that certain detectors require the use of hydrogen for fuel gas. Be sure to read *Using Hydrogen* in Chapter 4, *Plumbing the Gas Supply to the GC*, if you plan to use hydrogen with your TRACE system. *Testing for Leaks*, also in Chapter 4, contains information about leak testing to ensure that excessive amounts of flammable gases are not released into the lab atmosphere. The *TRACE Operating Manual* also discusses leak testing in detail.

Laboratories meeting the heating and cooling requirements specified in this manual will sufficiently circulate lab air to prevent accumulation of gases and fumes vented during normal GC use. Extensive leaks in plumbing lines to the GC may present hazards. Be sure to follow all local codes regulating plumbing of gases.

## Gas and Plumbing Requirements

---

You must provide the gas supplies for your gas chromatograph. Be sure to order your gases and regulators far enough ahead of time to have them ready for the GC installation process.



**WARNING!** All Thermo Fisher Scientific gas chromatographs are designed to use an inert gas as the carrier gas. If you wish to use hydrogen as a carrier gas, you must install a hydrogen sensor. Contact a Thermo Fisher Scientific sales representative if you plan to use hydrogen as the carrier gas in your new TRACE GC Ultra. If you don't have the hydrogen sensor, you must use an inert carrier gas.

Table 1-7 lists the gas recommendations for capillary column systems.

**Table 1-7. Capillary and Wide-Bore Column Gas Recommendations**

Detector Type	Carrier Gases	Fuel Gases	Make-Up Gas
FID <sup>1</sup>	Helium Nitrogen Hydrogen	Hydrogen + Air	Helium Nitrogen (if necessary)
NPD <sup>1</sup>	Helium Nitrogen Hydrogen	Hydrogen + Air	Helium Nitrogen
PID <sup>1</sup>	Helium Nitrogen Hydrogen	None	Helium Nitrogen
ECD <sup>1,2</sup>	Helium Nitrogen Argon	None	Nitrogen Argon/5% Methane
FPD <sup>1</sup>	Helium Nitrogen Hydrogen	Hydrogen + Air	Helium Nitrogen (if necessary)
TCD	Helium Nitrogen Hydrogen Argon	None	Same as carrier
PDD	Helium is the gas used for PDD discharge and carrier supply		

1. Maximum delivery pressure—1000 kPa. (145 psi) for carrier gas, 420 kPa (60 psi) for detector fuel gases.
2. Oxygen trap should be installed in gas lines.

Table 1-8 lists the gas recommendations for packed column systems.

**Table 1-8. Packed Column Gas Recommendations**

Detector Type	Carrier Gases	Fuel Gases	Make-Up Gas
FID <sup>1</sup>	Helium Nitrogen Argon	Hydrogen + Air	Not needed
NPD <sup>1</sup>	Helium Nitrogen	Hydrogen + Air	Nitrogen

**Table 1-8. Packed Column Gas Recommendations (Continued)**

Detector Type	Carrier Gases	Fuel Gases	Make-Up Gas
ECD <sup>1,2</sup>	Nitrogen Argon/5% CH <sub>4</sub>	None	Same as carrier gas (if necessary)
FPD <sup>1</sup>	Helium Nitrogen Argon	Hydrogen + Air	Not needed
TCD <sup>1,2</sup>	Helium Nitrogen Hydrogen Argon	None	Not needed
PDD	Helium is the gas used for PDD discharge and carrier supply		

1. Maximum delivery pressure—1000 kPa (145 psi) for carrier gas, 420 kPa (60 psi) for detector fuel gases.
2. Oxygen trap should be installed in gas lines.

## Gas Purity

If possible, you should use only instrument or chromatographic purity grade gases in your TRACE GC Ultra.

### Traps

UHP (Ultra-High Purity) gases should not contain impurities above 1 ppm. Impurities below 1 ppm generally do not require purification. Gases with higher impurity levels may require oxygen and hydrocarbon traps. A number of GC supply and accessory companies carry a variety of traps for gases.

See Figure 4-1, *Gas Trap Configuration*, on page 61, for the correct trap installation sequence. For more information on gas purification, contact your local Thermo Fisher Scientific CSE.

### Moisture Traps

Water in the carrier or fuel gas may damage the gas chromatograph column and contaminate the TRACE system. Water content should be less than 1 ppm in all cases. If you are using multiple traps, install the moisture trap closest the gas supply, before the hydrocarbon and the oxygen trap.

## Hydrocarbon Traps

Hydrocarbon traps remove organic materials from gases. If you are using multiple traps, install the hydrocarbon trap after the moisture trap, but before the oxygen trap.

## Oxygen Traps

Oxygen content in the carrier and gas lines should be less than 1 ppm. To achieve a level of oxygen of less than 1 ppm, install an oxygen-removing trap in the carrier gas line between the gas tank and the GC. If you are using multiple traps, the oxygen trap should be the last trap in the series.

## Purity Requirements

The following sections describe the minimum requirements for gases used in your gas chromatograph system. Always consider using UHP 99.999% pure gases when available.

### Helium

For carrier gas: 99.995%<sup>1</sup> high purity, with less than 1.0 ppm each of water, oxygen, and total hydrocarbons after purification. One full-size tank that has an outlet pressure of 400–700 kPa (60–100 psi). Use a regulator with a CGA 580 connection or equivalent. Use water, oxygen, and hydrocarbon traps. When PDD is used, helium must have a minimum purity of 99.999%, with < 20 ppm Ne impurity.

### Hydrogen

For carrier or detector fuel gas: 99.995%<sup>1</sup> high purity, with less than 1.0 ppm of total hydrocarbons after purification. One full-size tank that has an outlet pressure of 400–700 kPa (60–100 psi). Use a regulator with a CGA 350 connection or equivalent. Use water, oxygen and hydrocarbon traps.

### Air

For detector fuel gas: 99.995%<sup>1</sup> high purity. Use a regulator with a CGA 0590 connection or equivalent. Air compressors are not acceptable because they do not meet pressure, water, and hydrocarbon requirements.

---

1. 99.995% gas requires the use of appropriate traps.

**Nitrogen**

For carrier or make-up gas: 99.995% high purity, with less than 1.0 ppm of total hydrocarbons after purification. Use a regulator with a CGA 0580 connection or equivalent.

**Argon/5% Methane**

For ECD make-up gas: 99.995%<sup>1</sup> high purity. Use a regulator with a CGA 350 connection or equivalent.

**Servo Air**

For valve actuation and secondary cooling: Commercial grade or filtered air compressor. Large volume delivery at 400–500 kPa (60–80 psi), free of particles, oils, and water.

## Gas Regulators and Fittings

Gas tanks may be equipped with either single- or dual-stage regulators that contain stainless steel diaphragms. The regulator output pressure should be adjustable from 300 to 1000 kPa (45–145 psi). Each regulator should be equipped with a 1/8-in. Swagelok compression fitting, or equivalent. Figure 1-3 shows a dual-stage gas regulator with 1/8-in. fittings.

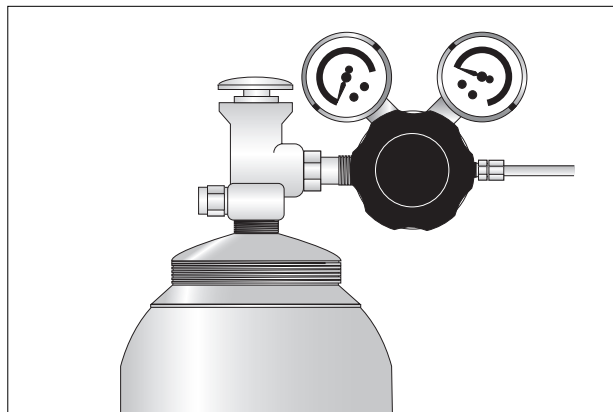

**Figure 1-3.** Dual-Stage Gas Regulator

Verify with your gas supplier the type of CGA fitting on the gas bottles you order. Be sure these fittings match the regulators described in [Purity Requirements](#) in

this chapter. If not, contact your gas supplier or your area Thermo Fisher Scientific sales representative to make the appropriate changes.

## Secondary Gas Regulators

Because secondary regulation of carrier, fuel, and make-up gases may be provided downstream of the cylinder regulator, a single- or dual-stage regulator is acceptable, but it must use a stainless steel diaphragm.

## Gas Tanks

Gas tanks should be placed where they cannot damage cables or gas lines. Use standard safety practices for securing gas tanks and bottles. Gas supply lines should terminate with 1/8-in. female Swagelok connectors.

Stored gases should be placed in an area where a wide temperature variation will not occur. Don't forget to plan for gas cylinder storage when preparing your laboratory.



**WARNING!** Do not place gas tanks in the path of the GC oven exhaust.

## Gas Lines

Gas lines should:

- be refrigeration grade, precleaned copper or new stainless steel
- be 1/8-in. or 1/4-in. diameter (gas lines longer than 3 m [10 ft] and supplying more than one GC should be 1/4-in.)
- be free of oil
- be free of moisture
- run to the back or side of the TRACE system
- be spliced with Swagelok fittings

### Precleaned tubing

Properly cleaned tubing is solvent-flushed and purge-dried with an inert gas, such as nitrogen or helium. Flush gas lines using acetone or hexane. Never use a

chlorinated solvent. When flushing gas lines, collect the solvent passing through the gas line and inspect it for discoloration or residue. Continue to flush gas lines until all waste solvent is free of discoloration and residue. Purge the gas line for several minutes to make sure the gas line is free of all traces of solvent.

### **DO NOT...**

- use any tubing other than new, clean metal tubing of the specified size
- allow any brazed or soldered plumbing joints to be made in the gas delivery system without precleaning
- allow pipe-threaded joints without PTFE tape as a sealant (no other thread sealant is acceptable)
- use PTFE tape on compression fitting joints (Swagelok fittings, or equivalent)
- mix components of one fitting brand with those of another brand (for example, Swagelok ferrules with Tylok body, etc.)

### **Gas Lines for Cold On-Column Injectors**

Gas chromatographs equipped with a cold on-column injector require secondary cooling performed by an extra air line with a high flow rate. This line should have an inside diameter of at least 2 mm (5/64 in.).

## **Cryogenic Cooling**

If you have purchased a cryogenic cooling option for your TRACE GC Ultra, you will need to provide a coolant supply. Your TRACE GC Ultra is already configured for either liquid nitrogen or liquid carbon dioxide. Be sure to identify which cryogenic cooling option your GC is configured for before you order cryogenic coolant.

## Liquid Nitrogen

Liquid N<sub>2</sub> must be supplied at pressures below 400 kPa (60 psi). Plumbing to the GC should be 1/4-in. copper or stainless steel tubing with insulation. It is your responsibility to ensure the liquid delivery connection from the liquid N<sub>2</sub> cryogenic supply is adaptable to 1/4-in. tubing. The liquid N<sub>2</sub> cryogenic valve on the TRACE GC Ultra is a 1/4-in. Swagelok fitting. Subambient operation of the PTV requires liquid N<sub>2</sub> cooling. Figure 1-4 shows the proper configuration for an N<sub>2</sub> tank.

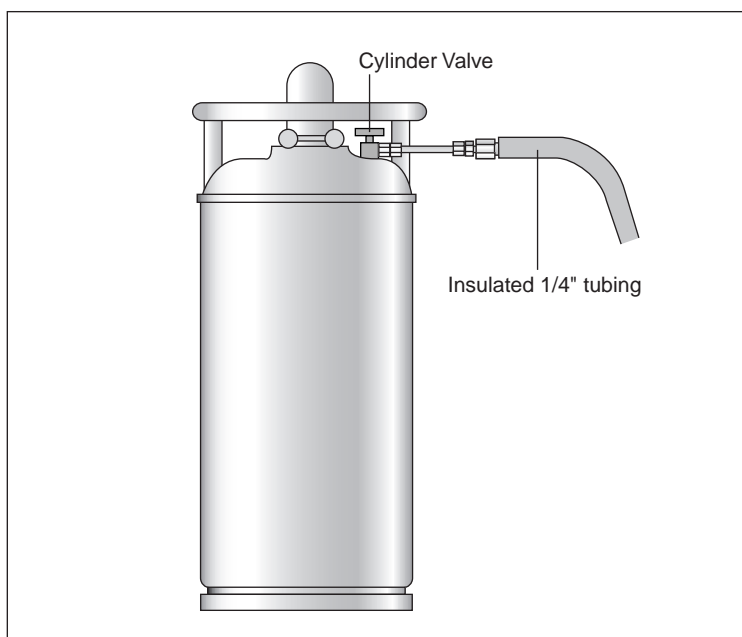

Figure 1-4. N<sub>2</sub> Tank Configuration



**WARNING!** High pressures and extremely low temperatures make liquid N<sub>2</sub> a hazardous material. High concentrations of N<sub>2</sub> in the air can cause asphyxiation hazard. To avoid injury, always follow the safety precautions and delivery system design recommended by your gas supplier.

## Liquid Carbon Dioxide

Liquid CO<sub>2</sub> must be supplied by a high-pressure cylinder with a dip tube. It is your responsibility to ensure the liquid delivery connection from the CO<sub>2</sub> cryogenic supply is adaptable to 1/8-in. tubing. The CO<sub>2</sub> cryogenic valve on the TRACE GC Ultra is a 1/8-in. Swagelok valve. Figure 1-5 shows the proper CO<sub>2</sub> tank configuration.

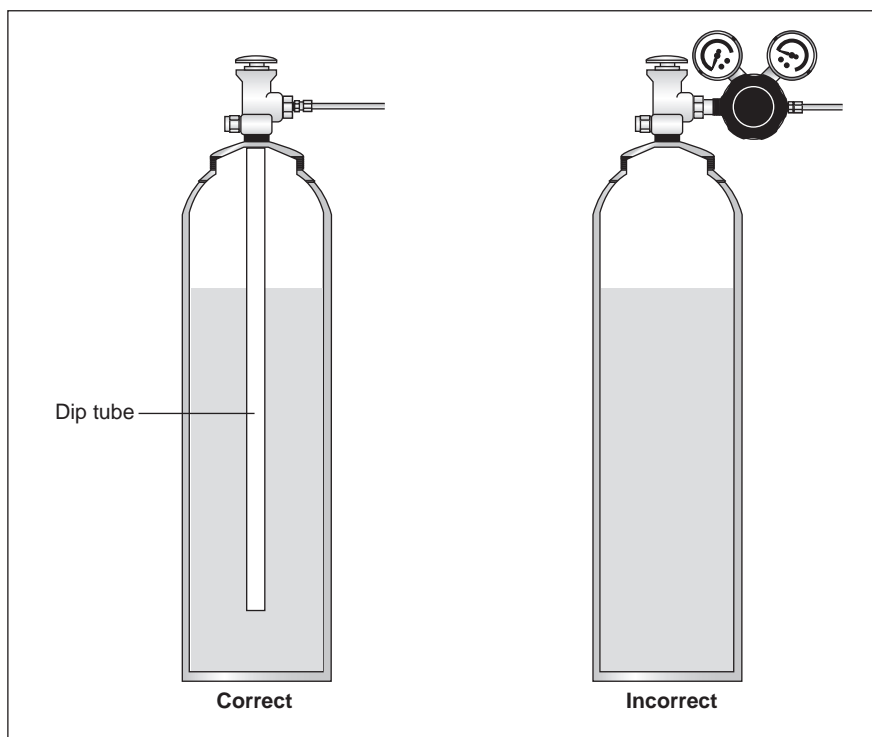

Figure 1-5. CO<sub>2</sub> Tank Configuration



**WARNING!** High pressures and extremely low temperatures make pressurized liquid CO<sub>2</sub> a hazardous material. High concentrations of CO<sub>2</sub> are dangerous. To avoid injury, always follow the safety precautions and delivery system design recommended by your gas supplier.

# Telephone

---

We recommend you install a telephone near the instrument so, if necessary, you can conveniently operate the system while speaking with Thermo Fisher Scientific Technical Support. (Refer to Appendix B, *Customer Communication*, for a list of Thermo Fisher Scientific offices worldwide.) The telephone line should accept digital transmissions for direct connection to the TRACE. The telephone outlet should be within 2 m (6 ft) of your system.

# Required Tools

---

The following tools are required for the installation and maintenance of your TRACE system. Some of them are supplied with the instrument.

- two 16 X 17 mm open-ended wrenches
- two 12 X 14 mm open-ended wrenches
- two 8 X 10 mm open-ended wrenches
- two 7 X 6 mm open-ended wrenches
- two 7/16 X 3/8-in. open-ended wrenches
- #1 and #2 cross-recessed (Phillips®) screwdrivers
- small and large common screwdrivers
- wire strippers
- 6-in. adjustable (Crescent®) wrench
- elbow (Channelok®) pliers
- a pen light
- steel rule tape
- Teflon® tape
- tweezers
- 12-in. adjustable (Crescent®) wrench
- 1/8-in. tubing cutter

- a gas flow meter
- Allen wrench set including 1.5 mm, 2 mm, 2.5 mm, 3 mm, 4 mm, 5 mm, and 6 mm wrenches

## Supplemental Equipment

---

The following items are supplemental equipment necessary for the installation of your TRACE system. Some of them are supplied with the instrument.

- carrier gas (refer to *Gas and Plumbing Requirements* on page 31 for information about the carrier gas requirements for your gas chromatograph)
- detector gas (refer to *Gas and Plumbing Requirements* on page 31 for the detector gas requirements for your gas chromatograph)
- dual-stage gas cylinder pressure regulators with an output pressure range of 0–1000 kPa (0–145 psi), stainless steel diaphragms, and a 1/8-in. Swagelok terminate nut
- sample syringe (5 or 10 µl)
- columns (a 7 m test column is supplied with each GC)
- tubing and fittings for carrier and detector gases (refer to *Gas Tanks* on page 36 for the tubing and fitting requirements for your gas chromatograph)
- spare septa
- column ferrules
- Swagelok<sup>®</sup> fittings
- leak detector (50/50 IPA/water solution or an electronic leak detector)
- data system or integrator (refer to *Hardware and Software Minimum Requirements* on page 42 for the data system requirements)



### NOTE

It is the responsibility of the customer to replace any consumables used during installation.

# Hardware and Software Minimum Requirements

---

Your TRACE GC Ultra produces analog and digital data output when you perform chromatographic analysis. A computer with a data system or a computing integrator can be used to process the data from the GC. The following topics provide the minimum requirements for computer hardware and operating systems depending on the data system you use to process the GC data.

## ChromQuest Data System

The ChromQuest data system has the following minimum computer requirements.

### Hardware Requirements

- 133 MHz Pentium processor
- 48 MB RAM
- 1 GB hard drive
- CD ROM
- mouse (serial port)



#### NOTE

Computer compatibility should not be assumed. The computer may not be included with the TRACE GC Ultra ChromQuest data system.

### Operating System Requirements

- Windows 2000/XP

## Chrom-Card Data System

The Chrom-Card data system has the following minimum computer requirements.

### Hardware Requirements

- 133 MHz Pentium processor
- 24 MB of RAM
- 1 GB hard drive
- CD ROM

### Operating System Requirements

- Windows 2000/XP



# Instrument Arrival

This chapter gives an overview of shipping and receiving procedures, installation, and training. The information in this chapter will give you an idea of what to expect when your TRACE system arrives.

Telephone and fax numbers for the Thermo Fisher Scientific offices are listed in Appendix B, *Customer Communication*.

## **Chapter at a Glance...**

Shipping Information.....	45
Installation.....	47
Training.....	48

## Shipping Information

---

Instruments are shipped in the manner agreed upon at the time of sale. There are two categories of shipping: *Origin* (FOB) and *Destination* (FOB, CIP, or CIF).

### **Origin**

For instruments shipped Ex-Works, also known as FOB (Free On Board) Origin, damages incurred in shipment are the responsibility of the purchaser and the carrier. However, Thermo Fisher Scientific will assist with filing claims and (billable) repairs, if necessary.

## Destination

There are two types of Destination shipping: CIP (Carriage and Insurance Paid to) Destination and CIF (Carriage Insurance and Freight paid to) Destination. These are also known as FOB Destination. For all types of Destination shipping, Thermo Fisher Scientific will file claims against the carrier for any damages incurred in shipment. Note, however, that Thermo Fisher Scientific will not accept liability for damage not recorded on the receiving documents.

## Receiving Instruments

Thermo Fisher Scientific instruments are shipped by electronic equipment carriers who specialize in the handling of delicate equipment. Occasionally, however, equipment inadvertently gets damaged in transit.

Please take the following precautions when receiving the instruments:

- Check carefully for obvious damage or evidence of rough handling, including triggering of Shockwatch<sup>®</sup> and Tiltwatch<sup>™</sup> labels.
- If external damage is apparent, note this fact on all copies of the receiving documents, and describe briefly the extent of the damage. The driver should sign (or initial) next to your comments to signify agreement with your observations. It may be necessary to photograph damaged areas for claims purposes. Contact the appropriate Thermo Fisher Scientific office to report the damage.
- Move the cartons to a protected location, preferably to the installation site.
- Leave the boxes as complete as possible, and do not unpack the components unless absolutely necessary.

The Customer Support Engineer (CSE) will also check for damage and verify the completeness of shipment. This will protect you in the event of missing or damaged components.



Freight insurance requires that obvious damage be noted on the receiving documents.

# Installation

---

If you have purchased the installation option, you must submit a completed Preinstallation Checklist (*Appendix A*) to us before a Thermo Fisher Scientific CSE will install your system.

The CSE will unpack and completely install the system, including optional instruments. The CSE will also initialize settings, verify that the system is operating according to specifications, and familiarize you with the system. Contact your local Thermo Fisher Scientific office for details.

If you have not purchased the installation option, refer to Section II, *Installation*, for installation instructions.

# Training

---

Valuable training on Thermo Fisher Scientific instruments and software is offered worldwide.

Experience has shown that maximum value can be derived from a scientific instrument if there is one person who has a major responsibility for the instrument.

We recommend that you designate a key operator to manage the operation and maintenance of the TRACE system. We also recommend that the key operator receive training at the Thermo Fisher Scientific Institute, at your site, or at one of the local Thermo Fisher Scientific offices.

For information on courses or enrollment, contact your local Thermo Fisher Scientific office:

**Thermo Electron S.p.A.**  
Strada Rivoltana km 4  
20090 Rodano (MI)  
ITALY  
39 02 95059 355

# SECTION

# II

## Installation

If you have purchased the installation option for your system, a Thermo Fisher Scientific authorized CSE (Customer Support Engineer) will install your system. If you have not purchased the installation option, this section will help you set up your TRACE GC Ultra. Included in this section are basic installation procedures you will need to be familiar with before you can install the GC.

Chapter 3, *Before You Begin...*, contains unpacking instructions and provides a brief tutorial of basic gas plumbing operations you must know before you can continue the installation process.

Chapter 4, *Plumbing the Gas Supply to the GC*, explains the proper gas supply connections and configuration for your GC.

Chapter 5, *Getting Connected*, explains the TRACE power connections and helps you mount and configure peripheral devices and data systems.



# Before You Begin...

This chapter contains unpacking instructions and a brief tutorial of basic gas plumbing operations you must know before you can continue the installation process.

## **Chapter at a Glance...**

Verify Site Preparation .....	51
Unpacking the Instrument .....	51
Gas Plumbing Basics .....	53

## Verify Site Preparation

---

Before the TRACE system can be installed, your laboratory must be in compliance with the guidelines and requirements in the *Site Preparation* section of this manual.

Use the *Preinstallation Checklist* in Appendix A to verify your laboratory conditions conform to the guidelines in Chapter 1, *Laboratory Preparation*, before you unpack your GC and begin the installation process.

## Unpacking the Instrument

---

You should have already inspected the exterior of the shipping container for damage as described in Chapter 2, *Instrument Arrival*. Carefully unpack the instrument and do the following:

1. Check the contents of each box or crate against the packing list to verify the shipment is complete.

2. Inspect each item for damage.
  - If equipment is damaged, keep boxes and their equipment in their existing condition and immediately notify the carrier.
  - Submit a damage claim directly to the carrier, and send a copy (including any shortage claims) to your authorized Thermo Fisher Scientific sales representative.
  - Do not return any equipment to the dealer or the factory without prior factory authorization.
3. Place the TRACE GC Ultra on your bench, allowing space to the rear of the instrument for venting.



**WARNING!** The TRACE GC Ultra is 47 kgs (105 lbs). Two people should lift the instrument onto the benchtop.

You should already have configured your laboratory according to the space requirements in Chapter 1, *Laboratory Preparation*, and the gas and power supplies should be accessible.

Optional equipment should be placed near the GC so you can connect it easily. After placing the TRACE on the bench, open the oven door and remove any packing material or other debris.

Before continuing with the installation, you should determine the following:

- the type of detector(s) installed on the GC
- the type of injector port(s) installed on the GC
- the type of carrier gas required for each detector
- the type of makeup gas required for each detector

Refer to *Gas and Plumbing Requirements* in Chapter 1, *Laboratory Preparation*, for a list of detector and injector gas requirements.

# Gas Plumbing Basics

---

In order to perform the procedures in this section properly, you must first have a working knowledge of a few basic gas plumbing operations. During the gas plumbing process, you will frequently perform the operations explained in the following sections.

## How to Use a Tubing Cutter

Use the following procedure to cut your gas supply tubing properly.

1. Attach the tubing cutter where you want to cut the tubing, and tighten the knob.
2. Rotate the cutter around the tubing and tighten the knob. Continue rotating and tightening the knob until you deeply score the tubing.
3. Remove the cutter, and snap the tubing in two.

## How to Use Teflon Tape on Pipe Threads

To ensure an inert seal around all tank and regulator pipe fittings, use the following procedure:

1. Wrap the tape around the pipe threads in a clockwise direction about three times. You should be able to tear the tape easily to separate it from the roll.
2. Make sure the tape does not extend past the threads or obstruct the pipe opening.
3. Make sure the tape does not twist or bunch up when you connect the pipe.



Do not use Teflon tape on Swagelok type compression fittings.

## How to Use Swagelok Tube Fittings

The Swagelok fitting consists of four components: a Swagelok nut, a back ferrule, a front ferrule, and an inlet body. It becomes a five-piece connection when affixed to the tubing. The two ferrules merge when the nut is tightened, forming a safe and leak-free seal between the tubing and body.

Use the following procedure to connect tubing using Swagelok fittings:

1. Place a Swagelok nut over the end of the tubing.
2. Place a back ferrule over the end of the tubing.
3. Place a front ferrule over the end of the tubing. If you are using tubing smaller than 1/8-in., make sure the tubing extends only 5 mm past the front ferrule. This will prevent damage to the fritted filter inside the inlet manifold. Figure 3-1 shows the proper assembly order.

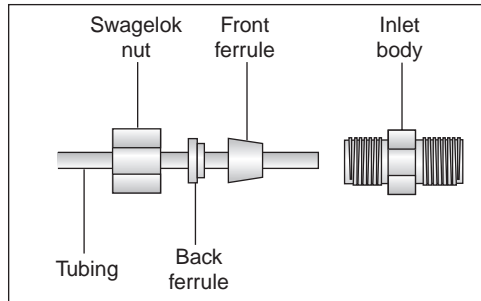

**Figure 3-1.** Swagelok Ferrule and Nut Assembly

4. Push the Swagelok nut over the ferrules.
5. Insert the tubing into the inlet body as far as it will go. If you are using tubing smaller than 1/8-in, make sure the tubing extends only 5 mm past the front ferrule when you insert it into the inlet body.
6. Slide the nut over the inlet body, as shown in Figure 3-2, and tighten until finger-tight.

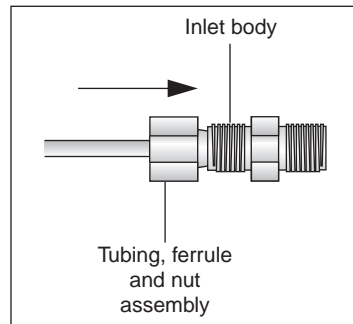

**Figure 3-2.** Swagelok and Inlet Connection

7. While holding the inlet body tightly with a backup wrench, tighten the nut about a  $3/4$  turn past finger-tight, as shown in Figure 3-3.

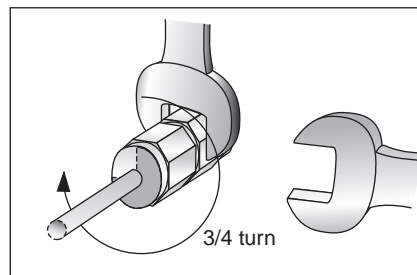

**Figure 3-3.** Tightening Swagelok Fittings



You can mark the nut before tightening. This will help you confirm that you have turned the nut a  $3/4$  turn.

## How to Attach a Swagelok Tee or Cross

To use a single gas source for more than one inlet or detector module, use a Swagelok tee or cross to split the gas flow. Use the following procedure to connect a Swagelok tee or cross:

1. Use a tubing cutter to cut gas supply tubing where you want to install the tee or cross.
2. Connect the tubing to the tee or cross with a Swagelok fitting, as described in *How to Use Swagelok Tube Fittings* on page 54.
3. Measure the distance from the tee or cross to the inlets or detectors, and cut tubing in the appropriate lengths.
4. Connect the tubing to the tee or cross ends with Swagelok fittings.
5. Install Swagelok caps on any open ends of the tee or cross that you do not plan to connect with tubing.

# Plumbing the Gas Supply to the GC

This chapter explains the proper gas supply connections and configuration information for your GC. Use the information in this chapter to connect your inlet and detector gas supplies.

## **Chapter at a Glance...**

Using Hydrogen.....	58
Connecting the Gas Supply Cylinders.....	60
Adding Traps to the Gas Supply.....	61
Purging Gas Lines .....	62
Connecting the Gas Supply to the Inlet Manifold.....	63
Connecting the Gas Supply to the Detector Manifold.....	63
Connecting Coolant to the Cryogenic System.....	66
Testing for Leaks .....	67

Before you begin plumbing gas to the GC, locate the main power cable and position it near the appropriate outlet. **Do not plug in the power cable at this time.** Follow the procedures in this section to build your gas supply lines for carrier, make-up, and detector gases.



### **CAUTION**

**DO NOT loosen or remove caps from the GC until you have purged your gas lines and are ready to connect them. Loosening or removing caps early will contaminate instruments and filters.**



**WARNING!** Hydrogen is a dangerous gas that, when mixed with air, may create an explosive mixture. The use of hydrogen as a carrier gas requires the operator's extreme caution. Special precautions must be taken because of the risk of explosion. The gas chromatograph must be equipped with a hydrogen sensor if you use hydrogen as a carrier gas. Refer to [Using Hydrogen](#) on page 58 for more information.

## Using Hydrogen

---

The use of hydrogen as a carrier gas or as fuel for certain flame detectors requires the operator's strict attention and compliance with special precautions due to the hazards involved.

Hydrogen is a dangerous gas, particularly in an enclosed area when it reaches a concentration corresponding to its lower explosion level (4% in volume). When mixed with air it can create an explosive mixture. An explosion hazard could develop in the GC oven when hydrogen is used as a carrier gas if oven elements are not perfectly connected to each other, or if the connection materials are worn out, broken, or otherwise faulty.

Use the following safety precautions when using hydrogen:

- Ensure that all hydrogen cylinders comply with the safety requirements for proper use and storage. Hydrogen cylinders and delivery systems must comply with local regulations.
- Make sure the gas supply is turned completely off when connecting hydrogen lines.
- Perform a *bubble test* to ensure that the hydrogen lines are leak-tight before using the instrument. Perform this test after the pressure test described in the [Testing for Leaks](#) portion of this chapter. Repeat this test to eliminate all leaks.
- Ensure your GC column oven has a Thermo Fisher Scientific hydrogen sensor. A hydrogen sensor continuously monitors the hydrogen level in the GC column oven.

If your GC oven does not have a hydrogen sensor already installed, contact your Thermo Fisher Scientific sales representative. To comply with

instrument safety requirements, a Thermo Fisher Scientific CSE or authorized service technician should install the sensor.

If you plan to use a sensor other than the recommended Thermo Fisher Scientific sensor, you must verify its ability to perform the functions listed above before installing it. It must comply with your local safety regulations, or with the IEC 61010<sup>1</sup> regulations if local regulations do not exist.

## Using the Hydrogen Sensor

The lower limit of the hydrogen sensor is 0.5% in volume. You should adjust the detection threshold to 1% in volume, which is 25% of the hydrogen lower limit of explosion (4% in volume).

In cases where the connections begin to leak or the column breaks, the sensor alerts the operator. Then it automatically cuts off the gas supply and heating to the active zones, and sweeps the column oven with forced air ventilation.

If the sensor detects anomalies or leaks during GC operation due to instrument malfunction, the operator must immediately:

- close the hydrogen supply
- switch off the gas chromatograph
- air out the room

The reliability of the sensor depends on careful maintenance. After the sensor is in use, you must periodically check its operating performance and calibration as recommended by the manufacturer. Refer to your hydrogen sensor's instruction manual for maintenance guidelines.



**WARNING!** Never use hydrogen in your TRACE system unless your GC oven has a hydrogen sensor installed.



**NOTE**

Thermo Fisher Scientific CSEs are not authorized to install or repair any instrument using hydrogen as a carrier gas unless the instrument is equipped with the appropriate sensor.

---

1. IEC 1010-1, First Edition, September 1990; IEC 1010-1, Amendment 1, September 1992; IEC 1010-1, Amendment 2, June 1995.

## Building the Gas Lines

---

Building the gas supply lines from the supply cylinders to the GC includes connecting the gas lines to the supply cylinders and adding any traps or filters to the line.

### Connecting the Gas Supply Cylinders

To properly connect the gas lines to the gas tanks, you will need the following materials:

- 1/8-in. copper tubing
- a tubing cutter
- 1/8-in. Swagelok nuts, and front and back ferrules
- two 7/16-in. X 3/8-in. open-ended wrenches
- Teflon<sup>®</sup> tape



**WARNING!** Secure gas cylinders to an immovable structure or wall. Handle and secure all gases according to local safety regulations.

Use the following procedure to connect regulators and tubing to the gas supply tanks:

1. Make sure the initial supply valves are turned off.
2. Connect the regulator to the gas supply tank. Fuel gas regulators have reverse threads. Use an open-ended wrench or adjustable Crescent wrench to tighten the regulator connection.
3. Determine the length of tubing you need. Use only enough tubing to connect the instrument to the gas supplies, but allow enough slack to allow the GC to be moved at least 40 cm (16 in.) from other equipment. This allows enough room to perform column connections and system maintenance. Also, be sure to account for tee connections.
4. Use a tubing cutter to cut the tubing.

5. Use a Swagelok tube fitting to attach the tubing to the gas outlet. Refer to *How to Use Swagelok Tube Fittings* in Chapter 3, *Before You Begin...*, for instructions on using Swagelok fittings.

## Adding Traps to the Gas Supply

You may wish to use traps, such as moisture or oxygen traps, in your gas supply line. Traps are especially necessary if you are unsure of the purity of your gas supplies. Refer to *Gas and Plumbing Requirements* in Chapter 1, *Laboratory Preparation*, for more information about gas purity requirements and appropriate traps for your GC. Figure 4-1 shows the proper order of traps in a gas supply line. Refer to your trap's instruction manual for specific purging and installation requirements.

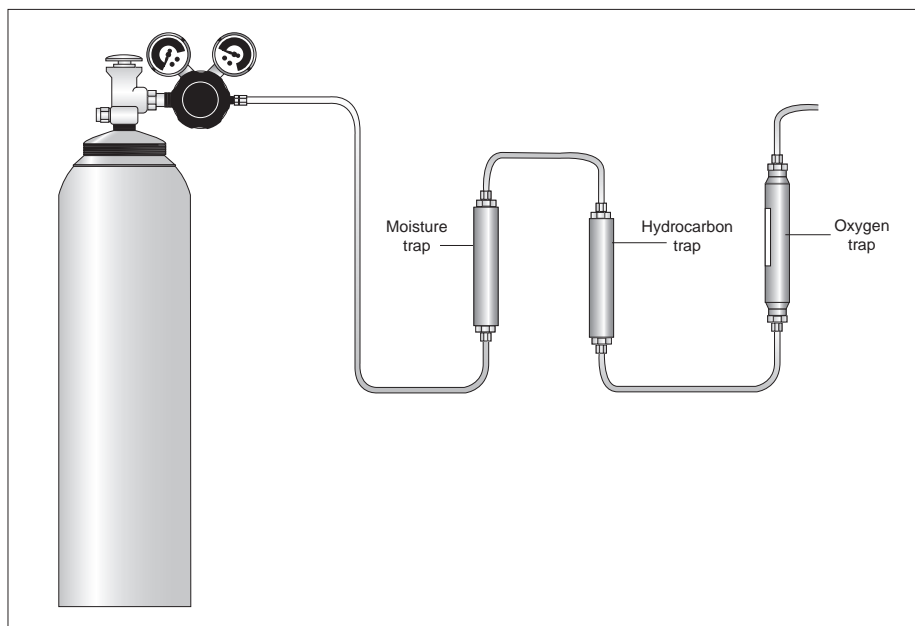

Figure 4-1. Gas Trap Configuration

Use the following procedure to attach traps to your gas line:

1. Determine the location for the trap in your supply line. Figure 4-1 shows the recommended trap order.
2. Use a tubing cutter to cut the tubing to the desired length.
3. Turn the gas regulator supply handle counterclockwise to reduce line pressure, then turn the gas supply on and increase the pressure to 35 kPa (5 psi) for about 15 seconds to purge the line of any unwanted debris.
4. Turn the gas supply off.
5. Use a 1/8" Swagelok fitting to connect the trap inlet to the gas supply tubing coming from the tank.
6. Turn the gas supply on to 35 kPa (5 psi) for about 30 seconds.
7. Turn the gas supply off.
8. Connect tubing to the trap outlet with a 1/8" Swagelok fitting.

Follow this procedure for all traps you wish to add to your gas supply line.

## Purging Gas Lines

---

You must purge the lines any time you make a cut in the tubing during the gas line assembly process. This will clear them of any debris from the cut. You will also need to purge the completely assembled gas lines, including any traps you plan to use, before you connect the your gas supply to the TRACE.

Use the following procedure to purge the gas lines:

1. Turn the gas supply on, and set the pressure to 35 kPa (5 psi).
2. Allow the line to purge for 10 minutes.
3. Turn off the gas supply.

## Connecting the Gas Supply to the Inlet Manifold

---

By now you should have done the following:

- completely built your gas line from your gas supply, including any traps, tees, and extra tubing to allow about 40 cm (16 in.) of slack in the line
- purged the gas line after every tube cut to remove any debris or contaminants

Use the following procedure to connect the gas line to the GC inlet manifold:

1. Make sure the gas supply is turned off.
2. Connect the gas line to the carrier gas inlet with 1/8-in. Swagelok fittings.



### NOTE

If the GC has been furnished with a 2x1 mm tube, use the ferrule for 2x1mm/1/8-in provided in the start-up kit.

Repeat the process if you are connecting the carrier gas supply to more than one inlet. Be sure to finish all inlet connections before turning on the gas supply.



### CAUTION

Inside each 1/8-in. inlet manifold is a fritted filter. If you connect a gas line smaller than 1/8-in. to an inlet, be sure the tubing *does not* touch the filter when inserted into the manifold. To keep the gas line from touching and possibly damaging the filter, extend the tubing only 5 mm past the front ferrule. This will ensure the tubing does not touch the filter. Refer to [How to Use Swagelok Tube Fittings](#) in Chapter 3, [Before You Begin...](#), for more instructions on using Swagelok ferrules and fittings.

## Connecting the Gas Supply to the Detector Manifold

---

Before you connect the detector gas line you should have done the following:

- built and connected the gas supply lines for your inlet gas supply, as described in [Building the Gas Lines](#) in this chapter

- completely built your detector gas line from your gas supply, including any traps, tees, and extra tubing to allow about 40 cm (16 in.) of slack in the line, as described in *Building the Gas Lines* in this chapter
- purged the gas line to remove any debris or contaminants, as described in *Purging Gas Lines* in this chapter

Use the following procedure to connect the gas line to the detector manifold:

1. Make sure the gas supply is turned off.
2. Connect each detector gas line to the appropriate detector gas bulkhead with 1/8-in. Swagelok fittings.



**NOTE**

If the GC has been furnished with a 2x1 mm tube, use the ferrule for 2x1mm/1/8-in provided in the start-up kit.

Different detector modules have different gas plumbing requirements. It is important that you connect the right gases to the right inlet fittings. The inlet fittings on the detector modules are labeled. Consult Table 4-1 on page 65 for the proper gas connections of the detector modules installed.

Repeat the process if you are connecting the detector gas supply to more than one bulkhead. Be sure to finish all detector connections before turning on the gas supply.



**CAUTION**

Inside each 1/8-in. detector manifold is a fritted filter. If you connect a gas line smaller than 1/8-in. to an detector manifold, be sure the tubing *does not* touch the filter when inserted into the manifold. To keep the gas line from touching and possibly damaging the filter, extend the tubing only 5 mm past the front ferrule. This will ensure the tubing does not touch the filter. Refer to *How to Use Swagelok Tube Fittings* in Chapter 3, *Before You Begin...*, for more instructions on using Swagelok ferrules and fittings.



**NOTE**

Refer to *Gas and Plumbing Requirements* in Chapter 1, *Laboratory Preparation*, for the type of gas appropriate for each detector.

**Table 4-1.** Detector Gas Connections

Detector	Installed Module	Connect Hydrogen to	Connect Air to	Connect Make-up Gas to <sup>a</sup>	Connect Sheath Gas to <sup>b</sup>	Connect Reference Gas to
FID	AB	Gas 2	Gas 1	—	—	—
	AC	Gas 2	Gas 1	Gas 3	—	—
	AD	Gas 3	Gas 1	—	—	—
ECD	AA	—	—	Gas 3	—	—
	AB	—	—	Gas 2	—	—
	AC	—	—	Gas 3	—	—
	AD	—	—	Gas 3	—	—
NPD	AD	Gas 2	Gas 1	Gas 3	—	—
PID	AB	—	—	Gas 2	Gas 1	—
	AC	—	—	Gas 3	Gas 1	—
	AD	—	—	Gas 3	Gas 1	—
FPD	AB	Gas 2	Gas 1	—	—	—
	AC	Gas 2	Gas 1	Gas 3 <sup>c</sup>	—	—
	AD	Gas 3	Gas 1	—	—	—
TCD	AB	—	—	Gas 2	—	Gas 1
PDD	Dedicated	---				Inlet

- For ECD detectors, the makeup gas is N<sub>2</sub> or 5% Ar/CH<sub>4</sub>.
- For PID detectors, the sheath gas is N<sub>2</sub> or He.
- FPD applications typically do not require Make-up gas.
- For PDD detector requires Helium must have a minimum purity of 99.999%, with < 20 ppm Ne impurity. For trace analysis of fixed gases, it is strongly recommended 99.9999% purity helium with < 0.5 ppm Ne. The discharge and the carrier gases must always flow through the helium purifier.

# Connecting Coolant to the Cryogenic System

---

The column oven and PTV (Programmable Temperature Vaporizing) injector cryogenic systems allow you to operate the GC at sub-ambient temperatures.

The cryogenic systems can reach the following temperatures:

- The column oven cryo system can reach  $-55\text{ }^{\circ}\text{C}$  with Liquid Nitrogen or  $-99\text{ }^{\circ}\text{C}$  with carbon dioxide.
- The PTV cryo system can reach  $-50\text{ }^{\circ}\text{C}$  with liquid nitrogen.

Use the following procedure to connect the coolant to your cryogenic system:

## Column Oven Cryo System

1. Connect the supply tubing to the  $\text{CO}_2$  or  $\text{LN}_2$  tank. Refer to Figures 1-4 and 1-5 in Chapter 1 for more information about cryo supply tanks.
2. Connect the other end of the supply tube to the 1/8 inch connector on the column oven cryo solenoid valve. The connector protrudes from the hole on the GC rear panel labeled **Sub Ambient Coolant**.

## PTV Injector Cryo System

If your GC has a PTV injector, use the following procedure to connect the cryo supply:

1. Connect the supply tubing to the  $\text{CO}_2$  or  $\text{LN}_2$  tank. Refer to Figures 1-4 and 1-5 in Chapter 1 for more information about cryo supply tanks.
2. Connect the other end of the supply tube to the 1/8 inch connector on the PTV cryo solenoid valve on the upper left corner of the GC rear panel.

# Testing for Leaks

---

Once you have connected your gas supplies to the GC inlets and detectors, you need to test the supply lines for leaks. Turn on your gas supply and use the following information to set the gas pressures for the leak test.

- Set the carrier gas pressure to approximately 50 kPa (7 psi) higher than the maximum pressure of the GC regulator.
- Set the detector gas pressures to approximately 350 kPa (50 psi).

Next you need to check all Swagelok fittings for leaks. Use the following procedure to check the fittings for leaks:

1. Use a handheld electronic leak detector (Sciences, Inc., Model LD-228, or equivalent) to check each fitting for leaks.
2. If you detect a leak, tighten the connection and retest it.
3. Repeat this process until all Swagelok connections are leak free.

**CAUTION**

**Do not use liquid soap leak detectors to check for leaks. Liquid soap leak detectors may contaminate you system. A mixture of 50% H<sub>2</sub>O/50% methanol or isopropyl alcohol may be used as a liquid leak detector.**



**WARNING!** Never use liquid leak detectors on or around electronic pneumatic circuits.



# Getting Connected

This chapter explains the TRACE power connections, and helps you mount and configure peripheral devices and data systems.

## **Chapter at a Glance...**

<a href="#">Introduction</a> .....	69
<a href="#">System Power Up</a> .....	77

## Introduction

---

If you plan to use any peripheral devices with your GC, such as an autosampler or data system, you will need to unpack them and follow any setup instructions included with them. Follow the instructions in the sections below to connect your peripheral devices to the GC.

### Remove the TRACE Cover

Before you can connect a data system or an autosampler, you must first remove the top cover of the GC using the following procedure:

1. Lift the detector cover off the GC top cover.
2. Open the oven door and unscrew the two top cover fastening screws.
3. Push the top cover back about 1 cm and lift it up and off the GC.

Figure 5-1 illustrates this procedure.

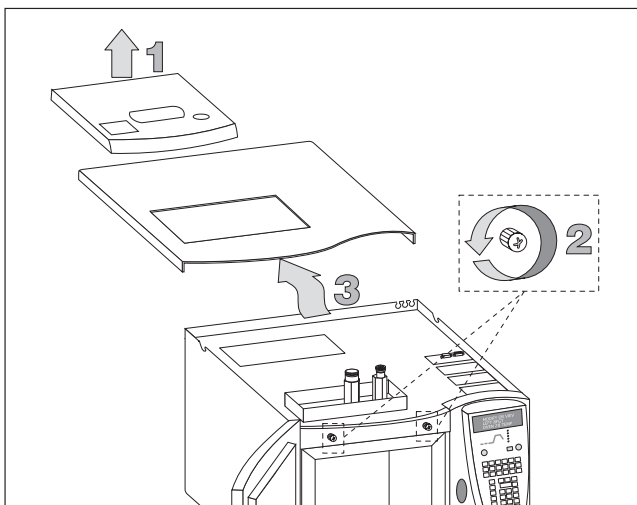

Figure 5-1. Removing the Top Cover

## Connect the Data System

There are two types of information transfer techniques between the TRACE GC Ultra and the computer: digital and analog. Use the following procedure to connect your data system computer to the GC for digital transfer:

1. Connect the computer, monitor, keyboard, mouse, printer (if applicable), and network connection (if applicable) according to the instructions in the accompanying documentation.
2. Plug in the computer, monitor, and printer power cables.
3. Connect your GC to the Thermo Fisher Scientific Corporation Data systems (ChromQuest, Chrom-Card, etc.) according to the CPU board, standard or LAN, installed into the GC, performing the relevant cables connection:
  - *Connect the Computer Cable*
  - *Connect the LAN Cable*

## Connect the Computer Cable

Perform this operation when the CPU standard board is installed into the GC.

- a. Connect the RS232 cable supplied with the data system to one of the COM ports of your computer, taking note of which port you use. You will need this information for software configuration.
- b. Connect the other end of the cable to the port on the top of the GC labeled **COMPUTER**.

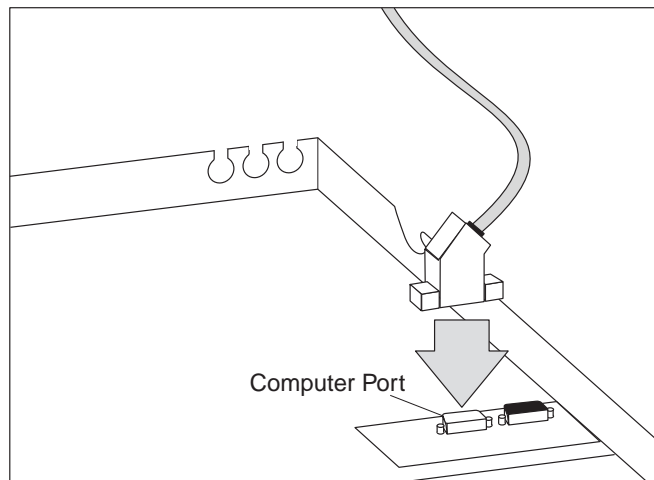

- c. Snap the cable securing ring into one of the cable slots on the GC.

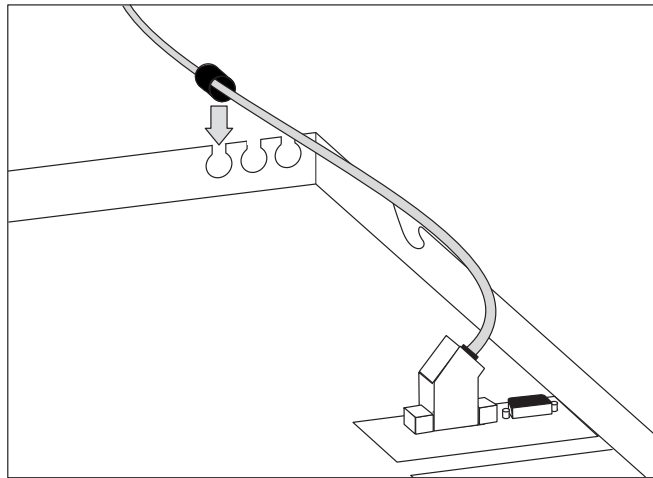

## Connect the LAN Cable

Perform this operation when the CPU/LAN board is installed into the GC.



For the LAN set-up refer to the [TRACE GC Ultra LAN Set-up User Guide](#).

- a. With the top cover removed, connect the LAN gray cable provided to the port on the top of the GC labeled LAN.

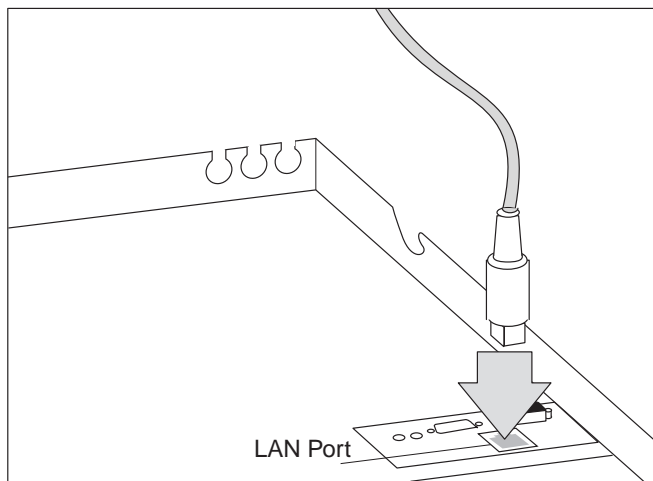

- b. Connect the other end of the cable to the LAN communication port of your computer.
- c. Snap the cable securing ring into one of the cable slots on the GC.

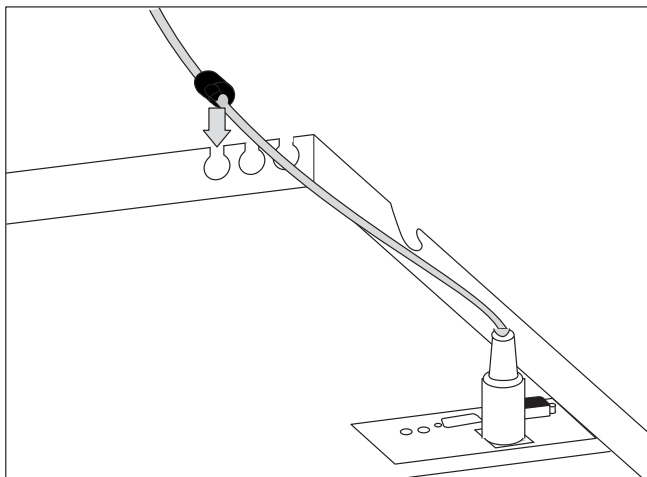

4. Turn on the GC (if it is not already on), the computer, the monitor, and the printer. Check the time, date, and monitor settings.
5. Test the printer and network connections and install drivers as necessary.
6. Refer to your data system's operating manual for instructions on configuring your data system and using it to control GC functions and process information from the GC.
7. Replace the top cover.

## Connect the Autosampler

You can connect an AS 2000 or HS 2000 autosampler to the TRACE GC Ultra. Use the following procedure to connect the autosampler cable to the GC:

1. Connect the RS232 cable, the DIN handshake cable, and the power cable supplied with the autosampler to the autosampler control module.

2. With the top cover removed, connect the RS232 cable to the port on the top of the GC labeled AUTOSAMPLER.

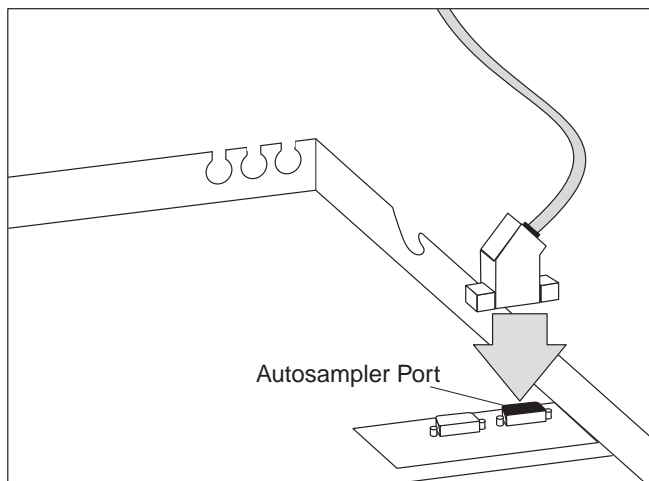

or

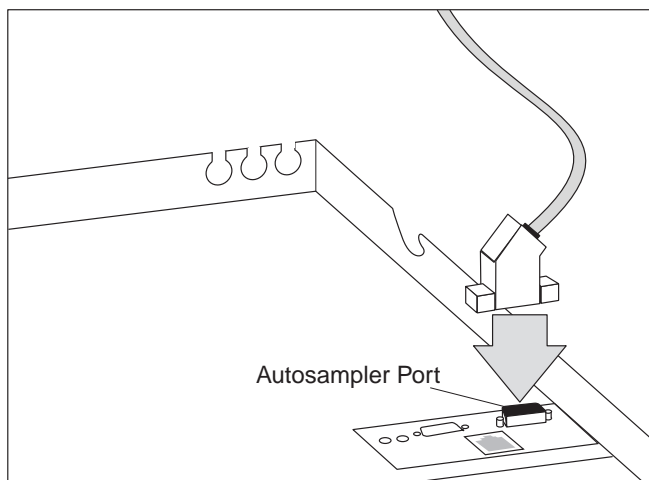

3. Snap the cable securing ring into one of the cable slots on the GC.

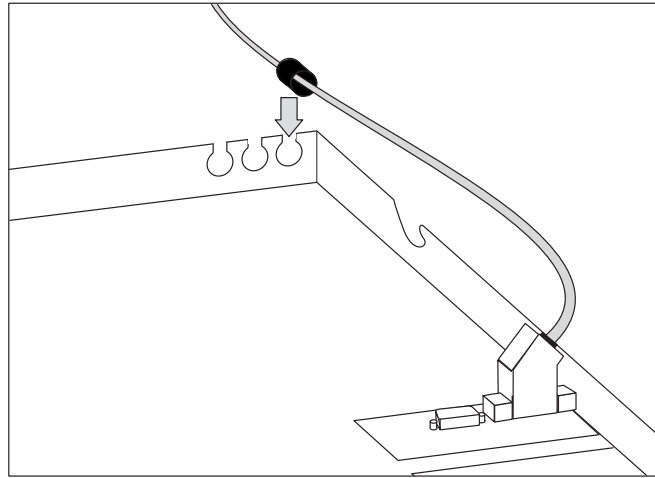

or

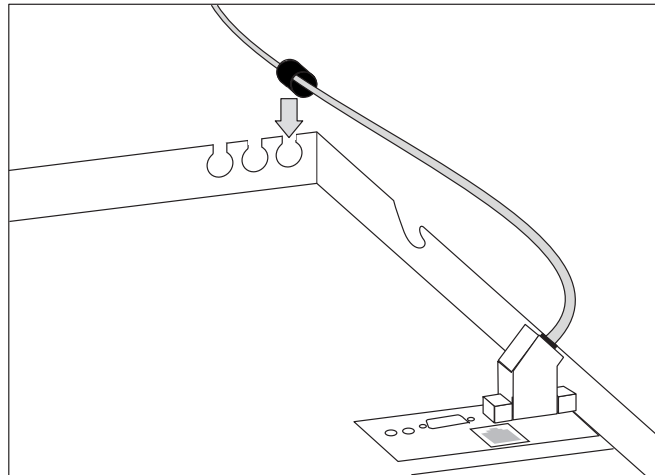

4. Connect the handshake cable to the **AUTOSAMPLER DIN** port on the rear of the GC.
5. Replace the top cover.

If the GC and autosampler are on, the GC will automatically recognize the autosampler. Refer to the autosampler operating manual for instructions on mounting the autosampler turret and tray on top of the GC, and for configuration instructions.

## Computing Integrators

Setup your integrator and connect it to a power supply according to the manufacturer's instructions. Each TRACE GC Ultra comes with shielded two-conductor cables for each detector analog output, and a remote ready inhibit, start, and stop cable (handshake cable). The two-conductor cables consist of a blue positive wire, a white negative wire, and a shield wire. The handshake cable has a DIN connector on one end (for connection to the rear panel of the GC), and leads on the other (for connection to the integrator).

The blue positive (+) and white negative (-) wires of the two-conductor cable connect the detector output and the integrator. Figure 5-2 shows the cable connections.

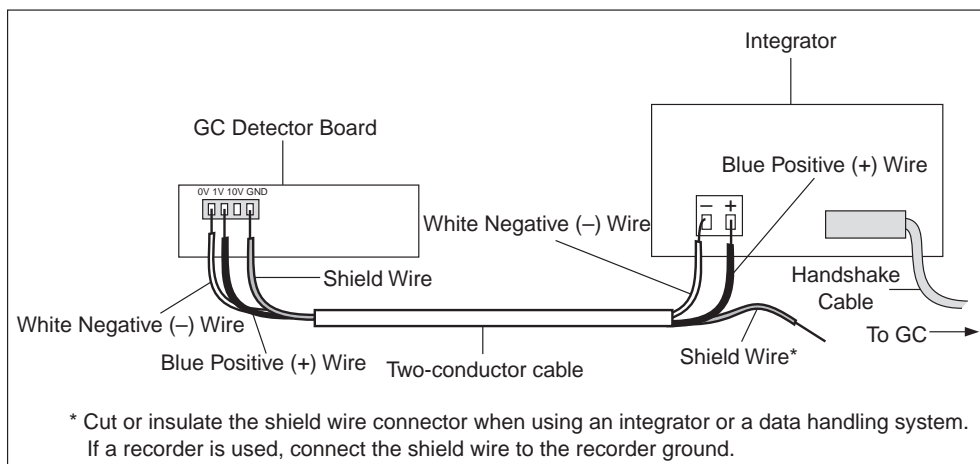

**Figure 5-2.** Integrator Cable Connections

Refer to your integrator's operating manual for instructions on using the integrator to process information from the GC.

# System Power Up

---

By now your lab should be equipped with the proper power supply and outlets as described in *Power Requirements* in Chapter 1, *Laboratory Preparation*. You also should have completed the gas supply plumbing procedure, as described in Chapter 4, *Plumbing the Gas Supply to the GC*.

If you have not already done so, connect the power cord to the GC. Plug the power cord into the appropriate power outlet. The power switch is located on the back side of the GC. Flip the switch to the ON position.

If the detectors are not already installed on your TRACE GC Ultra, you will need to install them now. Refer to the *TRACE GC Ultra Operating Manual* for more information about installing detectors.

You will need to install a column in the GC. Refer to the *TRACE GC Ultra Operating Manual* for more information about installing columns.

For system test information, refer to the *TRACE GC Ultra Standard Operating Procedures Manual*, and to the user manuals of any accessories you have connected to your TRACE GC Ultra system.



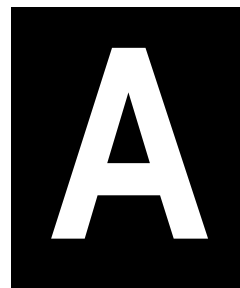

# Preinstallation Checklist

This appendix contains a step-by-step list of items you should complete before your TRACE GC Ultra arrives. Please complete the checklist after reading the *Site Preparation* section. This will ensure that your site is suitable for the installation of your new TRACE GC Ultra. Please contact a Thermo Fisher Scientific Customer Support Engineer (CSE) if you encounter any difficulties preparing your site for installation.

- Ensure that entrances and hallways are at least 92 cm (37 in.) across.
- Ensure that your workbench space is at least 1.5 m (4.5 ft) across and can support a 75 kg (170 lb) load.
- Ensure that the instruments can be placed on surfaces that do not vibrate.
- Ensure that your work area has proper lighting.
- Provide an acceptable power source for your TRACE system.
- Provide a wall outlet configuration that meets specifications.
- Ensure that the temperature in your laboratory is between 18 and 35 °C (65 and 95 °F).
- Ensure that the relative humidity level in your laboratory is between 40 and 80%, with no condensation.
- Ensure that the air in your laboratory is free of excessive dust, smoke, or other particulate matter.

Appendix A  
**Preinstallation Checklist**

- Ensure that your system is free of electrostatic discharge.
- Provide an adequate exhaust system.
- Ensure that you meet appropriate gas line requirements.
- Install a telephone near your system.

Fax or mail the TRACE *Preinstallation Checklist* to the appropriate Thermo Fisher Scientific office.

You can refer to Appendix B, *Customer Communication*, to select the Thermo Fisher Scientific office nearest you.

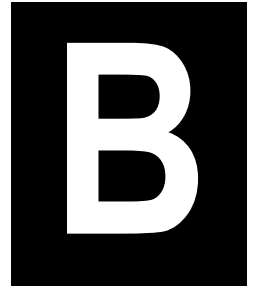

# Customer Communication

Thermo Fisher Scientific provides comprehensive technical assistance worldwide and is dedicated to the quality of our customer relationships and services.

## How To Contact Us

---

This appendix contains contact information for Thermo Fisher Scientific office. Use the list reported in *Customer Communication* to contact your local Thermo Fisher Scientific office or affiliate.

**Thermo Electron S.p.A**  
INTERNATIONAL SALES DEPARTMENT  
Strada Rivoltana  
20090 Rodano - Milano

Tel: +39 02 95059 226  
Fax: +39 02 95059 256

**Thermo Electron S.p.A**  
INTERNATIONAL CUSTOMER SUPPORT  
Strada Rivoltana  
20090 Rodano - Milano

Tel: +39 02 95059 373  
Fax: +39 02 95059 225

This appendix also contains a one-page [Reader Survey](#). Use this survey to give us feedback on this manual and help us improve the quality of our documentation

## Reader Survey

**Product:** TRACE GC Ultra  
**Manual:** Site Preparation and Installation Manual  
**Part No.:** A31709190-1

**Please help us improve the quality of our documentation by completing and returning this survey.  
Circle one number for each of the statements below.**

	Strongly Agree	Agree	Neutral	Disagree	Strongly Disagree
The manual is well organized.	1	2	3	4	5
The manual is clearly written.	1	2	3	4	5
The manual contains all the information I need.	1	2	3	4	5
The instructions are easy to follow.	1	2	3	4	5
The instructions are complete.	1	2	3	4	5
The technical information is easy to understand.	1	2	3	4	5
Examples of operation are clear and useful.	1	2	3	4	5
The figures are helpful.	1	2	3	4	5
I was able to install the system using this manual.	1	2	3	4	5

**If you would like to make additional comments, please do. (Attach additional sheets if necessary.)**

---

---

---

---

**Fax or mail this form to:**

Thermo Electron S.p.A.  
Strada Rivoltana km 4  
20090 Rodano (MI)  
ITALY  
Fax: 39 02 95059388

# Glossary

This glossary lists and defines terms used in this guide. Included are abbreviations, acronyms, metric prefixes, and symbols.

## A

A	ampere
ac	alternating current
ADC	analog-to-digital converter

## B

b	bit
B	byte (8 b)
baud rate	data transmission speed in events per second

## C

°C	Celsius
CIP	Carriage and Insurance Paid To
cm	centimeter
CPU	central processing unit (of a computer)
CSE	Customer Service Engineer

## D

<i>d</i>	depth
DAC	digital-to-analog converter
dc	direct current
DS	data system

## Glossary

### E

ECD	Electron Capture Detector
EMC	electromagnetic compatibility
ESD	electrostatic discharge

### F

°F	Fahrenheit
FID	Flame Ionization Detector
FOB	Free on Board
FPD	Flame Photometric Detector
ft	foot

### G

g	gram
GC	gas chromatograph
GND	electrical ground

### H

<i>h</i>	height
h	hour
harmonic distortion	A high-frequency disturbance that appears as distortion of the fundamental sine wave
HV	high voltage
Hz	hertz (cycles per second)

**I**

IEC	International Electrotechnical Commission
impulse	See <i>transient</i>
in.	inch
I/O	input/output

**K**

k	kilo ( $10^3$ or 1024)
K	Kelvin
kg	kilogram
kPa	kilopascal

**L**

<i>l</i>	length
L	liter
LAN	Local Area Network
lb	pound
LED	light-emitting diode

**M**

m	meter (or milli [ $10^{-3}$ ])
M	mega ( $10^6$ )
$\mu$	micro ( $10^{-6}$ )
min	minute
mL	milliliter
mm	millimeter

## Glossary

m/z	mass-to-charge ratio
<b>N</b>	
n	nano ( $10^{-9}$ )
NPD	Nitrogen Phosphorous Detector
<b>O</b>	
$\Omega$	ohm
<b>P</b>	
p	pico ( $10^{-12}$ )
Pa	pascal
PCB	printed circuit board
PDD	Pulsed Discharge Detector
PID	Photo Ionization Detector
PN	part number
psi	pounds per square inch
<b>R</b>	
RAM	random access memory
RF	radio frequency
ROM	read-only memory
RS-232	industry standard for serial communications

**S**

s	second
sag	See <i>surge</i>
slow average	A gradual, long-term change in average RMS voltage level, with typical durations greater than 2 s
SOP	Standard Operating Procedures
surge	A sudden change in average RMS voltage level, with typical duration between 50 $\mu$ s and 2 s

**T**

TCD	Thermal Conductivity Detector
transient	A brief voltage surge of up to several thousand volts, with a duration of less than 50 $\mu$ s

**U**

UFM	Ultra Fast Module
-----	-------------------

**V**

V	volt
V ac	volts, alternating current
V dc	volts, direct current
VGA	Video Graphics Array

**W**

w	width
W	Watt



## A

- Air
  - purity 34
- Air conditioning
  - humidity 29
  - particulate matter 30
  - temperature 27
  - user's responsibility 27
- Altitude 29
- Ammonia
  - carrier gases 35
- Argon/5% Methane
  - purity 35
- Autosamplers
  - heat output 28
  - weight 22

## C

- Capillary columns
  - gases 32
- Carrier gases 32
  - ammonia 35
- CGA fittings 35
- ChromCard
  - minimum requirements
    - hardware 43
    - operating system 43
- ChromQuest
  - minimum requirements
    - hardware 42
    - operating system 42
- Cold on-column injectors
  - gas lines 37
- Computer
  - heat output 28
  - power 26
  - weight 22
- Coolant 37
  - liquid carbon dioxide 39
    - hazards 39
  - liquid nitrogen 38
    - hazards 38
- Cryogenic cooling 37
  - liquid carbon dioxide 39
    - hazards 39

- liquid nitrogen 38
  - hazards 38

## CSE

- installation 47

## D

- Data System
  - ChromCard 43
  - ChromQuest 42
  - minimum requirements 42
- Detectors
  - gases 32
- Doorways 20
- Dust 30

## E

- ECD
  - gases
    - capillary and wide-bore columns 32
    - packed columns 33
- Electrostatic discharge 30
- Elevators
  - entrance 20
- Entrance 20
- Equipment
  - required 40
  - supplemental 41
- Exhaust system 31
- Ex-works. See *Shipping, origin.*

## F

- FID
  - gases
    - capillary and wide-bore columns 32
    - packed columns 32
- Floors
  - vibration 30
- Flushing gas lines 36
- FPD
  - gases
    - capillary and wide-bore columns 32
    - packed columns 33
- Freight insurance 46
- Frequency
  - power 23

## Index

Fuel gases 32

### G

Gas lines 36

cold-on column injectors 37

fittings 37

requirements 37

Gases

carrier 32

detectors 32

fuel 32

gas lines 36

cold on-column injectors 37

pre-cleaned tubing 36

requirements 37

gas tanks 36

storage 36

make up 32

packed columns 32

plumbing basics 53, 54, 56

cutting tubing 53

Swagelok fittings 54

Swagelok tees and crosses 56

Teflon tape 53

purity 33–35

air 34

argon/5% Methane 35

helium 34

hydrogen 34

nitrogen 35

servo air 35

recommendations 32

regulators 35

secondary 36

supplies 31–33

traps 33

hydrocarbon 34

moisture 33

oxygen 34

water background 33

Ground 23

### H

Hardware

minimum requirements 42

Harmonics 24

Heat output

autosamplers 28

computer 28

monitor 28

optional instruments 28

printers 28

TRACE GC 28

Helium

purity 34

Humidity

low/high 29

static discharge 29

Hydrocarbon traps 34

Hydrogen

exhaust 31

purity 34

sensor 31

warning 31

### I

Installation 47

Customer Service Engineer 47

equipment

required 40

supplemental 41

purchase option 47

Installation kit

replacement of consumables 41

Instrument arrival 45

freight insurance 46

### L

Laboratory entrance

shipping container 20

Lighting 30

Liquid carbon dioxide 39

hazards 39

Liquid nitrogen 38

hazards 38

### M

Minimum dimensions

entrance 20

Minimum requirements

hardware 42  
Moisture traps 33

**N**

Nitrogen  
  purity 35  
NPD  
  gases  
    capillary and wide-bore columns 32  
    packed columns 32

**O**

Operating environment  
  user's responsibility 27  
Optional instruments  
  heat output 28  
  power requirements 26  
Overvoltage category 24  
Oxygen traps 34

**P**

Packed columns  
  gases 32  
Particulate matter 30  
PID  
  gases  
    capillary and wide-bore columns 32  
Plugs  
  international 25  
  USA 25  
Plumbing gases  
  cutting tubing 53  
  Swagelok fittings 54  
  Swagelok tees and crosses 56  
  Teflon tape 53  
Pollution 31  
Power  
  120 V ac 23  
  230 V ac 23  
  current requirements  
    optional instruments 26  
    printers 26  
    standard system 26  
  frequency 23  
  harmonics 24

quality of 23  
sags and surges 24  
slow average 24  
technical assistance 27  
transients or impulses 24  
voltage disturbances 23  
wall outlets 24

Power supply  
  UPS 25

Printers  
  heat output 28  
  power 26  
  weights 22

**R**

Regulators 35  
Required tools 40

**S**

Sags 24  
Secondary gas regulators 36  
Servo air  
  purity 35  
Setting up the instrument 52  
Shipping 45  
  container 20  
  damage 46  
  destination 46  
  origin 45  
Site preparation  
  preinstallation checklist 51  
  user's responsibility 20  
  verifying 51  
Slow average 24  
Solvent  
  in gas lines 36  
Static discharge  
  See *Electrostatic discharge*  
Sub-ambient operation 37  
Supplemental equipment 41  
Surges 24  
Swagelok fittings 54  
Swagelok tees and crosses 56

## Index

### T

#### TCD

gases

capillary and wide-bore columns 32

packed columns 33

#### Technical assistance

line power problems 27

See also *Customer service*

#### Teflon tape 53

#### Telephone 40

support 40

#### Temperature

air conditioning 27

laboratory, optimum 27

See also *Heat output*

system reliability 27

#### Tools 40

#### Training 48

#### Transients or impulses 24

#### Tubing cutter 53

### U

#### unpacking 51

#### UPS

power supply 25

#### User's responsibilities

air conditioning 27

operating environment 27

quality of power 27

spares 41

### V

#### Vibration 30

#### Voltage disturbances

harmonics 24

sags and surges 24

slow average 24

transients or impulses 24

#### Voltages

120 V ac 23

230 V ac 23

USA 23

Worldwide 23

### W

#### Wall outlets

GC connections 26

#### Weights

computer 22

optional instruments 22

printers 22

TRACE system 22

#### Wide-bore columns

gases 32

#### Workbench 22

## List of Figures

Figure 1-1.	NEMA 5-20P and 5-15P Power Plugs and Outlets: 120 V ac .....	25
Figure 1-2.	Shuco 230 V ac Power Plugs and Outlets .....	25
Figure 1-3.	Dual-Stage Gas Regulator .....	35
Figure 1-4.	N <sub>2</sub> Tank Configuration .....	38
Figure 1-5.	CO <sub>2</sub> Tank Configuration .....	39
Figure 3-1.	Swagelok Ferrule and Nut Assembly .....	54
Figure 3-2.	Swagelok and Inlet Connection .....	55
Figure 3-3.	Tightening Swagelok Fittings.....	55
Figure 4-1.	Gas Trap Configuration .....	61
Figure 5-1.	Removing the Top Cover .....	70
Figure 5-2.	Integrator Cable Connections .....	76



## List of Tables

Table 1-1.	Minimum Space and Weight Requirements: TRACE Standard System.....	22
Table 1-2.	Space and Weight Requirements: TRACE Optional Instruments.....	22
Table 1-3.	Maximum Current Requirements for the TRACE Standard System .....	26
Table 1-4.	Maximum Current Requirements for TRACE Optional Instruments .....	26
Table 1-5.	Heat Output: TRACE Standard System .....	28
Table 1-6.	Heat Output: TRACE Optional Instruments .....	28
Table 1-7.	Capillary and Wide-Bore Column Gas Recommendations.....	32
Table 1-8.	Packed Column Gas Recommendations.....	32
Table 4-1.	Detector Gas Connections .....	65

